



ADVANCED SUSPENSION TECHNOLOGY

**AUTOMOTIVE  
ROAD & TRACK**



2020



## HISTORY

Ever since the company was founded in 1976, Öhlins has represented the very pinnacle of suspension technology and firmly rooted itself as an intricate part of the motorsport industry, underpinning countless world titles. That very technology has subsequently been adopted not only as the gold standard of aftermarket suspension, but is also by car and motorcycle manufacturers around the world.

Back in the 1960's, Kenth Öhlin was an up-and-coming motocross rider and showed an innate talent for mechanics. He knew how to bring the best out of his material and soon he saw himself engaged in modifying his competitor's bikes. By the time he started his business he had already designed exhaust pipes, engines and – of course – shock absorbers.

Öhlins soon became synonymous with advanced suspension. The products were not only superior in terms of technology, but as Mr. Öhlin was, and is, a very meticulous man the quality was always outstanding. The first world championship was won already in 1978, as Russian Gennady Moiseev took the 250cc title on an Öhlins equipped KTM. Since then, more than another 350 world titles have followed. The success continued in road racing and soon also in the automotive segment, in racing as well as in rally, all adding to the motorsport pedigree. But don't think that Öhlins was content, not for a minute. The company continued to grow, adding electronically controlled, semi-active suspension to its portfolio under the trademark CES. Today, this technology has revolutionized the car industry and can be found in a wide range of products from premium car manufacturers.

In the 1980's, Öhlins' achievements got the attention of industrial giants and in 1987, Öhlins was acquired by Yamaha. Under the Japanese ownership, Öhlins had the necessary financial stability to develop into a dominating player in the industry. Twenty years later, Öhlins was considered better off on its own legs and Kenth Öhlin regained the company he once had started.



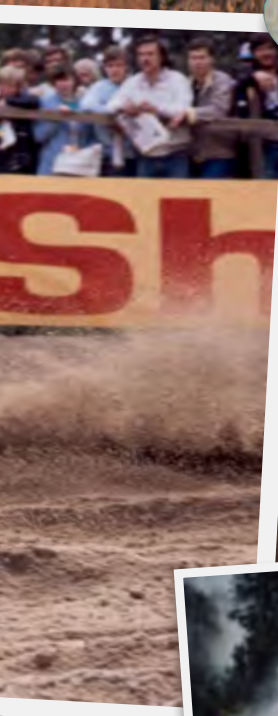

PASSION,  
PERFORMANCE,  
PERFECTION.



# OTHER PRODUCT AREAS



MOTORSPORT



MX & ENDURO



MOTORCYCLE



MOUNTAIN BIKE

# WHAT WE LEARNED FROM MOTORSPORT

Competition improves the breed they say. Wise words, but here at Öhlins, competition created the breed. We are a company that has been clearly focused since day one, with a singular purpose: To win races. From Kenth Öhlins' first simple design back in 1976, through to the computer designed and tested masterpieces that we now create, every Öhlins unit is designed to give you total control, even on the very edge of the performance envelope. As our engineers say 'The ground gives better traction than air.' so every Öhlins design has one clear remit: to keep the car, bike, ATV or snowmobile maximizing traction, cornering speed and control! That is how you win races.

We enjoy a two-way dialogue with all of the teams we support. Kenth Öhlin made a clear decision many years ago, that we would never give any product away free to teams in sponsorship. Not one thing. So, every team that you see winning on Öhlins is doing so through choice, not obligation. The fact that so many teams choose to decline free product to pay for ours perhaps tells you what you need to know about the quality and ability of Öhlins race suspension products.

Over 300 world titles have been achieved on Öhlins, and many thousands of podiums. Every discipline from Touring and GT-cars, through to prototypes, Formula 1 and

Indycars. From the WRC through to World Superbikes, MX-GP and MotoGP. In every instance we work closely with the team's technical division in a two-way flow of information that allows us both to analyze data and evaluate performance. This is then poured back into the design and creation of new products as well as the continual improvement of existing lines. Winning races has taught us a lot, and these lessons are directly transferred into our aftermarket programmes where the real enthusiasts can benefit from the very best in forks, steering dampers or suspension.

Motorsport means so much to us. We have over 30 employees solely dedicated to high-end racing support and service. This team regularly briefs our designers on their results 'in the field' to ensure that every Öhlins customer, whether they're a Factory Le Mans team – or a single, discerning enthusiast gets the very best performance from their machine.

We test everything – and then we test again. But data can only tell you so much. At Öhlins, it has always been as much about 'feel' as it has been about the numbers. If it feels 'right' to the driver or rider, then that is even more important than the dry statistics. We're drivers too, and once you have driven on the product, you'll feel the difference.

A man is seen from the back, wearing a black t-shirt with a large yellow Öhlins logo. The logo consists of the word "ÖHLINS" in a bold, stylized font with a registered trademark symbol, enclosed in a yellow rectangular border with rounded corners. Below the logo, the text "ADVANCED SUSPENSION TECHNOLOGY" is printed in a smaller, sans-serif font. The man is standing in a workshop or garage, with a laptop computer visible to his left. Another person wearing a blue cap is partially visible to the right. The background is slightly blurred, showing the interior of a building with white walls and ceiling.

**ÖHLINS®**

ADVANCED SUSPENSION TECHNOLOGY



Spring position

# ÖHLINS TTX-TECHNOLOGY

Öhlins Racing developed the Twin Tube (TTX) technology back in 2002, first used in formula racing series. Since then, the TTX-technology has been developed further to maximize the performance on the track and are now widely featured in all top-level racing. With the TTX-technology you receive the highest level of suspension technology, a real racing product.

The TTX products comes in a variety of dimensions, lengths and designs, all tested by our qualified test drivers. With the individual adjusters for the compression- and rebound valve you have the best possible option to set up your car for the track day.

When driving on the limit, it puts immense stress on your equipment, tires, suspension, brakes, bushings etc. Öhlins TTX-technology allows you to push the car to the limit.

Shock absorbers can experience loss of damping, cavitation when pushed over the limit of optimal performance. With Öhlins TTX-technology we are proud to say that we have eliminated cavitation with our unique design. The TTX-technology always keeps the pressure balanced within the shock absorber. Hence you will never experience a pressure drop or loss of damping performance when pushing your car to the limit to set the fastest laptime.

The Öhlins TTX shock absorbers are racer friendly shock absorbers, easy to set up, dial in and rebuild. Support is always available from the Öhlins distributors worldwide.



**STX**

## ÖHLINS STX-TECHNOLOGY

The STX-series are a high-pressure monotube type shock absorber. The fluid is under gas pressure and is kept separated by a dividing piston. The pressurisation prevents cavitation of the oil, and the shock absorbing action is, therefore, more even. Öhlins shock absorbers with external rebound adjustment have integrated temperature compensation. The shock absorbing effect is consequently independent of the temperature. The more advanced models permit individual adjustment of compression and rebound damping.

Öhlins shock absorbers provide the possibility of adjustment, making them adaptable to most vehicles, drivers and ranges of use. All of the shock absorbers with springs have adjustable preload of the spring action. The Öhlins STX shock absorbers are racer friendly shock absorbers, easy to set up, dial in and rebuild. Support is always available from the Öhlins distributors worldwide.



# THE FEATURES OF DFV TECHNOLOGY



So what is DFV? It is Dual Flow Valve technology – and it sets us apart from our competitors. Only Öhlins has DFV technology on its road and track products.

With DFV, the oil gets an extra passageway which is active in an intermediate speed range. The damping force in this speed range influences comfort to a large degree, but does not affect handling so much. Therefore the damping can be tuned to increase comfort without negatively impacting handling. The DFV can also open during high accelerations, which for instance means that the wheel can return quickly to the ground after a sharp bump, providing grip and traction. The new Öhlins R&T range uses DFV technology on every single fitment, making it the perfect upgrade for the enthusiast that needs comfort and agility in one unit.

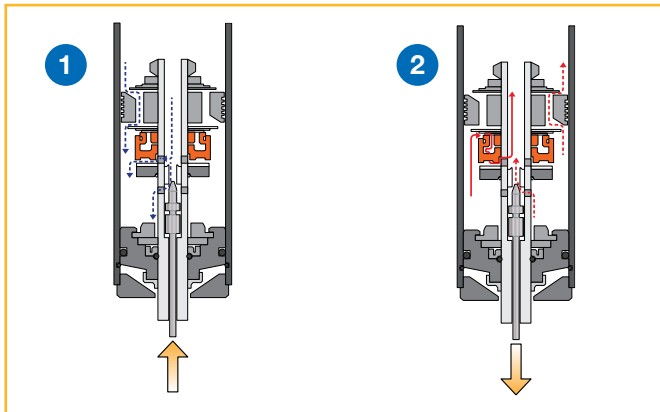

**FIGURE 1:** (Compression flow) At low shaft speeds, oil flows mostly through the shaft jet bleed (lower dotted arrow). At high shaft speeds, oil flows mostly through the compression ports in the piston (upper dotted arrow). At intermediate shaft speeds, which are very critical for comfort, or during sudden shaft accelerations, oil can also escape through the compression ports in the DFV (solid arrow), increasing comfort.

**FIGURE 2:** (Rebound flow) At low shaft speeds, oil flows mostly through the shaft jet bleed (lower dotted arrow). At high shaft speeds, oil flows mostly through the rebound ports in the piston (upper dotted arrow). At intermediate shaft speeds, which are very critical for comfort, or during sudden shaft accelerations, oil can also escape through the rebound ports in the DFV, increasing comfort and maintaining tyre contact with the road.

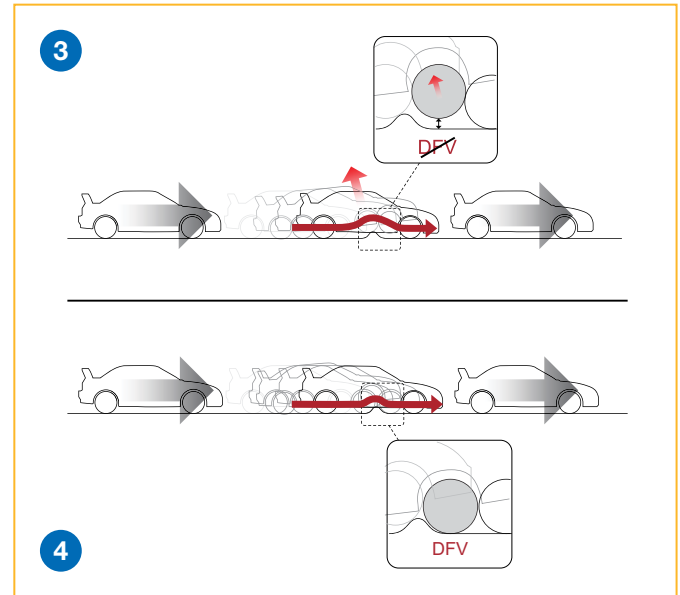

**FIGURE 3:** (Vehicle – no DFV) Without DFV the oil can not flow through the piston quickly enough on the rebound stroke after hitting a bump, so the tyre is not able to stay in contact with the road.

**FIGURE 4:** (Vehicle – DFV technique) The DFV valve opens, letting the oil flow quicker through the piston on the rebound stroke after hitting a bump, enabling the tyre to stay in contact with the road.

When adjusting ride height on coilover units, it's worth comparing how it's done. On many inferior designs, height is adjusted by raising or lowering the lower spring platform. This has the effect of compressing or extending the spring, which can limit the suspension travel that may cause topping out. The Öhlins method is to leave the spring seat in its perfect position, whilst the lower flange spins easily on the threaded body, to allow you to adjust with absolute precision whilst maintaining the perfect characteristics that we took so long to design in! Once you've set it all up, the adjuster simply locks off to maintain your exact settings.



FIGURE 5: Thermal Expansion

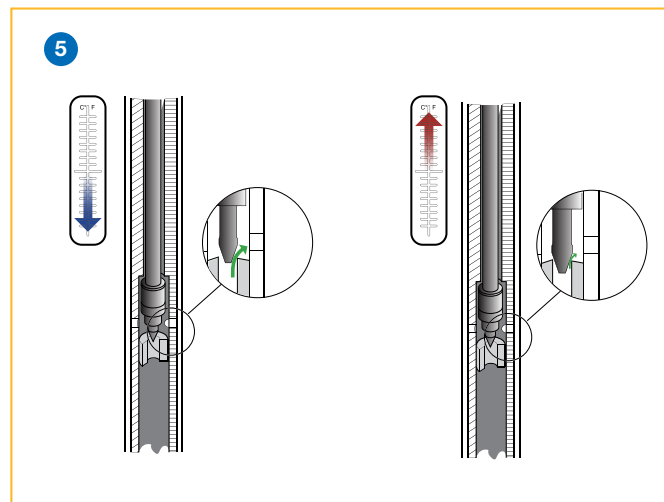

Dampers will get hot. That's one thing that you can be sure of. As the piston moves within the damper, it generates friction – and therefore, heat. Although we can't stop heat, we can deal with it, and this is yet another way that Öhlins differs from the competition. As the heat increases, the viscosity of the damper fluid can change, altering the car's handling characteristics. Our unique needle bleed valve expands with temperature, closing the gap that the fluid travels through, maintaining a consistent damping rate. The best thing of all? You won't even notice! All you'll feel is that the car responds consistently, lap after lap, turn after turn. Allowing you to concentrate on braking points and apexes whilst the Öhlins technology takes care of the damping.

These kits all work well 'out of the box', but there's still plenty of adjustment for you to set things your way. You like stiff and reactive? Or soft and forgiving? It's all there. Too much low speed rebound damping can have an adverse effect on grip, so the easily accessible adjuster at the base of the Öhlins units allows small, but positive increments of fine tuning, so you can take into account every single parameter. Sounds complicated? Nothing could be further from the truth. Just a few clicks either way from our factory settings will soon have your car responding precisely to your inputs and driving style.

The Road & Track McPherson struts also feature camber adjustable upper and lower mounts to give you the possibility to fine tune your wheels for the right occasion – whether you want to go for a ride in your neighborhood or take your car for a spin at the track on a weekend.





# ÖHLINS ROAD & TRACK THE CONCEPT

Perfection in performance. That has been the Öhlins way since 1976. We have achieved this through an obsession with detail and quality. Every part of the Öhlins manufacturing process sets new standards for the automotive industry. Whether it's material choice, design, manufacture or even a small detail like packaging. Only when it is perfect can it leave the factory. Our Road & Track range puts Öhlins incredibly high standards of research, development and manufacture within the reach of the discerning enthusiast. This range is pure Öhlins, but the good news is – you won't need a race team budget to afford it!

For us, the relationship with our customers is usually a long and fruitful one. We have supplied many of the top teams in motorsport, but also thousands of genuine enthusiasts. We only manufacture to one quality and every new client is as important as the last. In our view, the relationship doesn't end with that initial sale. We see our role as providing support and back up thereafter, for as long as our client needs it. That's why all Öhlins units are fully serviceable and adjustable, making sure that they give faithful and dynamic service for years to come. Our fully trained and approved service centers can make your old Öhlins units perform like new and even make changes in damper characteristics to suit your set-up preferences.

Remember that our road and track range was born out of our Motorsport programme, where the impossible has to be made possible, so you can expect the same level of care and attention to detail on the R&T range. The choice of materials used is one of the key factors behind Öhlins success. Each component is surface treated to ensure reduced friction and

superior performance. The piston shaft and damper walls are micro-finished and plateau honed for optimum lubricity and low friction coefficient. This attention to detail is the same across the entire range of Öhlins products. Without this fine surface finishing, excessive friction can reduce the compliancy of the damper causing a loss of function.

Damping rate on the R&T units is fully adjustable and ties compression and rebound together as a matched setting, meaning that in 99% of cases, the units will work superbly, straight 'out of the box' with only the smallest adjustments required to suit the car or drivers individual preferences. Despite what other suspension manufacturers may tell you, comfort is king, even when you are trying to set-up a competition machine. Our vast experience in motorsport events around the globe has shown us that the fastest drivers and riders are those who aren't being shaken to bits as they go flat out. The 'science of compliance' is a hugely important part of our design work. And last but not least, is durability. But hey, we're Swedish, so chances are you have already guessed that we're used to building components that survive one of the toughest environments in the World. The carbon steels bodies are salt spray tested and can service 240 hours of abuse, whilst still retaining function. Don't let those stunning race car looks fool you. These are real-world units for daily driven cars.

That is probably why our Road & Track products have proven to be as popular with manufacturers making the ultimate track day car as they are for aftermarket tuners and drivers wanting to upgrade the chassis performance of their cars even further.

# ÖHLINS ROAD & TRACK DEVELOPMENT PROCEDURE

Ever wondered how Öhlins development process works when we develop a Road & Track kit? Then, continue reading and be amazed how much work we put into every new application.

It's a step by step process which starts with our test drivers drives the car on public roads just outside Stockholm, and on our racetrack to set a benchmark. The goal is to collect enough data about the current setup from driving on the racetrack and public roads.

What data is of our interest? We measure all specific parameters of the suspension, such as the motion ratios, ride-height, roll-centre etc. We are also performing a corner-weight of the car. This data is vital for the next stages of our development process.

With our purpose-built software, we develop an initial setting with feedback from our test drivers. From the first setting, we can begin to build an early proposal damper-setting and spring stiffness.

When the computer-based model is developed, it's time to build and fit the first Öhlins Road & Track prototypes to the car.

With the prototypes fitted to the car our technicians and engineers hand over the car to our test drivers again. A first shakedown performed on the racetrack to make sure that we have a safe product.

After the shakedown, we begin to stress the dampers with high-speed maneuvers, and we also find out if the computer modelling of our

damper-settings and spring stiffness are correct. Though our dampers are primarily intended to be used on the racetrack, our engineers and test drivers spend much time to find a comfort-setting for road use. The Road & Track dampers from Öhlins are often more comfortable than the standard suspension.

The process to find the optimum track setting and road setting may take some time. Öhlins is a perfectionist company, and that is clear in our development process. If our test drivers and engineers are not pleased with a particular setting, they change it until they are sure that this is the best possible match between Road & Track.

The final step in the Öhlins Road & Track Development Process is to finalise and prepare the dampers for production. All documentation and prototypes used during the development phases are saved for regulatory compliance to meet legal demands.

The Öhlins Road & Track Development Process is executed for every single car model. Every setting is tailor-made and evaluated thoroughly before being transferred to series production. Our test drivers put in thousands of test kilometres to ensure the perfect handling combined with comfort. We develop our dampers after careful calculations to secure a high-quality product, which is safe to use when driving on the absolute edge. All in all, Öhlins Road & Track group takes care of testing and development to find the optimum performance so you can focus on driving your car with a smile! Drive safe!



**ÖHLINS**  
ADVANCED SUSPENSION TECHNOLOGY



---

## ÖHLINS HALL OF FAME

Öhlins Racing won its first World Championship Title in 1978 with Gennady Moiseev in the 250cc Motocross championship. From that day, Öhlins has won world championships titles every year, first in Motocross, later in Superbike classes and Auto motorsport championships such as WRC with Mitsubishi, Endurance, VLN, GT-Racing, Touring cars and Formula racing series. 2017 Öhlins teamed up together with Specialized, the Mountainbike manufacturer, to challenge the best for the world title. Öhlins took the title in both the ladies and the men's championship the first time we participated. The rest is history...

[OHLINS.COM](http://OHLINS.COM)



# CUSTOMER SUCCESS STORIES



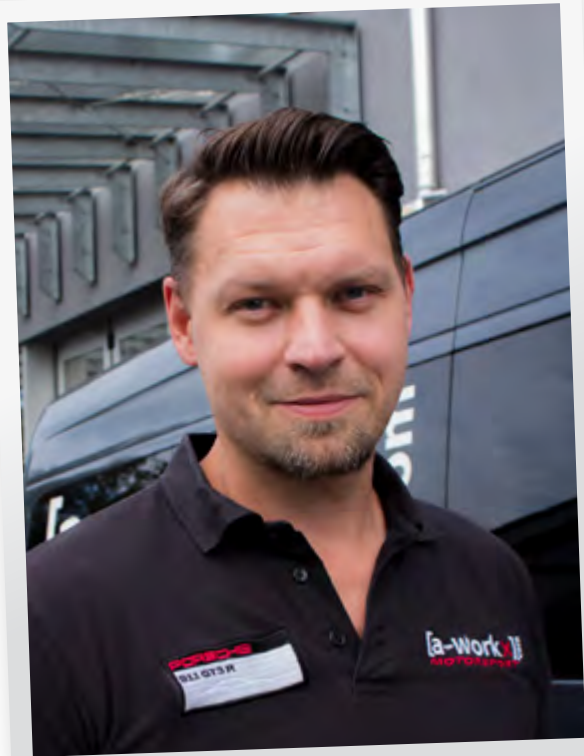

“I participate track days almost every second weekend. The Öhlins dampers feel very prestige and stabile on the track but also on the road as well. I wouldn't ever believe that Road & Track dampers could feel so comfortable on both grounds.”

---

## NIKO WIETH

Race engineer, Team Owner [a-workx], Racing Driver  
Munich, Germany

# NEWS

## 2020



**AUDI**  
R8  
PAGE 27



**BMW**  
1-SERIES  
PAGE 31



**HYUNDAI**

i30 N

**PAGE 48**



**LAMBORGHINI**

HURACÁN /  
HURACÁN PERFORMANTE

**PAGE 50**



**PORSCHE**

911

**PAGE 70**

## ROAD & TRACK

# AUDI

A3 • S3 • RS3

**DFV**



**YEAR MODEL:** A3 2003-2012, S3 2006-2012, RS3 2011-2012

**CHASSIS CODE:** 2<sup>ND</sup> GEN, 8P • **PART NO:** VWS MT10



### FEATURES

- > DFV (Dual Flow Valve)
- > McPherson strut (55 mm width) **FRONT**
- > Conventional shock absorber **REAR**
- > Single bleed adjuster
- > Height adjustable (approx. 20 mm lower than standard)
- > Choose your desired spring rates
- > Recommended spring (70 N/mm) **FRONT**
- > Recommended spring FWD (70 N/mm), 4WD (80 N/mm) **REAR**
- > Use with original top mounts
- > Rebuildable
- > Weight reduction compared to original suspension: -10 kg
- > Corrosion salt spray tested (ISO 9227)
- > 2 year limited warranty
- > Cancellation kit available. For more info see page 107.
- > TÜV approved application



**OHLINS.COM**

## ROAD & TRACK

# AUDI

A3 • S3 • RS3



**YEAR MODEL:** A3 2012-2020, S3 2013-2020, RS3 2015-2020

**CHASSIS CODE:** 3<sup>RD</sup> GEN, 8V • **PART NO:** VWS MT21



### FEATURES

- > DFV (Dual Flow Valve)
- > McPherson strut (55 mm width) **FRONT**
- > Conventional shock absorber **REAR**
- > Single bleed adjuster
- > Height adjustable (approx. 20 mm lower than standard)
- > Choose your desired spring rates
- > Recommended spring (70 N/mm) **FRONT**
- > Recommended spring FWD (70 N/mm), 4WD (80 N/mm) **REAR**
- > Use with original top mounts
- > Rebuildable
- > Weight reduction compared to original suspension: -10 kg
- > Corrosion salt spray tested (ISO 9227)
- > 2 year limited warranty
- > Cancellation kit available. For more info see page 107.
- > TÜV approved application



## ROAD & TRACK

# AUDI

A4 • S4 • RS4



**YEAR MODEL:** A4 2008-2016, S4 2008-2016, RS4 2012-2016

**CHASSIS CODE:** B8 • **PART NO:** AUS MS00



### FEATURES

- > DFV (Dual Flow Valve)
- > McPherson strut **FRONT**
- > Conventional shock absorber **REAR**
- > Single bleed adjuster
- > Height adjustable (approx. 20-25 mm lower than standard)
- > Choose your desired spring rates
- > Recommended spring (120 N/mm) **FRONT**
- > Recommended spring (50 N/mm) **REAR**
- > Use with original top mounts
- > Rebuildable
- > Weight reduction compared to original suspension: -9 kg
- > Corrosion salt spray tested (ISO 9227)
- > 2 year limited warranty
- > Cancellation kit available. For more info see page 107.



[OHLINS.COM](http://OHLINS.COM)

## ROAD & TRACK

# AUDI

A5 • S5 • RS5



**YEAR MODEL:** A5 2007-2016, S5 2007-2017, RS5 2010-2017

**CHASSIS CODE:** B8 • **PART NO:** AUS MS00



### FEATURES

- > DFV (Dual Flow Valve)
- > McPherson strut **FRONT**
- > Conventional shock absorber **REAR**
- > Single bleed adjuster
- > Height adjustable (approx. 20-25 mm lower than standard)
- > Choose your desired spring rates
- > Recommended spring (120 N/mm) **FRONT**
- > Recommended spring (50 N/mm) **REAR**
- > Use with original top mounts
- > Rebuildable
- > Weight reduction compared to original suspension: -9 kg
- > Corrosion salt spray tested (ISO 9227)
- > 2 year limited warranty
- > Cancellation kit available. For more info see page 107.



## ROAD & TRACK

# AUDI

R8

TTX

**YEAR MODEL:** 2006-2015

**CHASSIS CODE:** 1<sup>ST</sup> GENERATION (V8, V10) • **PART NO:** AUV MS00



### FEATURES

- > TTX-technology
- > Conventional shock absorber
- > 2-way adjustable
- > Height adjustable (approx. 0 - 20mm lower than standard)
- > Choose your desired spring rates
- > Recommended spring (140 N/mm) <sup>FRONT</sup>
- > Recommended spring (140 N/mm) <sup>REAR</sup>
- > Rebuildable
- > Weight reduction compared to original suspension
- > Corrosion salt spray tested (ISO 9227)
- > 2 year limited warranty
- > Cancellation kit available. For more info see page 107.



OHLINS.COM

ROAD & TRACK

NEW



AUDI

R8

TTX

YEAR MODEL: 2015-2019

CHASSIS CODE: 2<sup>ND</sup> GENERATION • PART NO: AUV MT00



#### FEATURES

- > TTX-technology
- > Conventional shock absorber
- > 2-way adjustable
- > Height adjustable (approx. 0 - 10mm lower than standard)
- > Choose your desired spring rates
- > Recommended spring (160 N/mm) <sup>FRONT</sup>
- > Recommended spring (160 N/mm) <sup>REAR</sup>
- > Rebuildable
- > Weight reduction compared to original suspension: -8 kg
- > Corrosion salt spray tested (ISO 9227)
- > 2 year limited warranty
- > Cancellation kit available. For more info see page 107.





## ROAD & TRACK

# AUDI

## TT • TTS • TT RS



**YEAR MODEL:** TT 2006-2014, **TTS** 2008-2014, **TT RS** 2009-2014  
**CHASSIS CODE:** 8J • **PART NO:** WWS MT10



### FEATURES

- > DFV (Dual Flow Valve)
- > McPherson strut (55 mm width) **FRONT**
- > Conventional shock absorber **REAR**
- > Single bleed adjuster
- > Height adjustable (approx. 20 mm lower than standard)
- > Choose your desired spring rates
- > Recommended spring (70 N/mm) **FRONT**
- > Recommended spring FWD (70 N/mm), 4WD (80 N/mm) **REAR**
- > Use with original top mounts
- > Rebuildable
- > Corrosion salt spray tested (ISO 9227)
- > 2 year limited warranty
- > Cancellation kit available. For more info see page 107.



[OHLINS.COM](http://OHLINS.COM)

## ROAD & TRACK

# AUDI

## TT • TTS • TT RS



**YEAR MODEL:** TT 2014-2020, **TTS** 2014-2020, **TT RS** 2014-2020

**CHASSIS CODE:** FV/8S • **PART NO:** VWS MT21



### FEATURES

- > DFV (Dual Flow Valve)
- > McPherson strut (55 mm width) **FRONT**
- > Conventional shock absorber **REAR**
- > Single bleed adjuster
- > Height adjustable (approx. 15 mm lower than standard)
- > Choose your desired spring rates
- > Recommended spring (70 N/mm) **FRONT**
- > Recommended spring FWD (70 N/mm), 4WD (80 N/mm) **REAR**
- > Use with original top mounts
- > Rebuildable
- > Corrosion salt spray tested (ISO 9227)
- > 2 year limited warranty
- > Cancellation kit available. For more info see page 107.





ROAD & TRACK

**BMW**

1M



**YEAR MODEL:** 2011-2013

**CHASSIS CODE:** E82 • **PART NO:** BMZ MN01



### FEATURES

- > DFV (Dual Flow Valve)
- > McPherson strut **FRONT**
- > Conventional shock absorber **REAR**
- > Single bleed adjuster
- > Height adjustable (approx. 15 mm lower than standard) **FRONT**
- > Height adjustable (approx. 5 mm lower than standard) **REAR**
- > Coil springs (60 N/mm) **FRONT**
- > Coil springs (110 N/mm) **REAR**
- > Use with original top mounts
- > Rebuildable
- > Corrosion salt spray tested (ISO 9227)
- > 2 year limited warranty
- > TÜV approved application



**OHLINS.COM**

ROAD & TRACK

NEW



# BMW

## 1-SERIES



**YEAR MODEL:** 2004-2011

**CHASSIS CODE:** E81, E82, E87, E88 • **PART NO:** BMS MI01

### FEATURES

- > DFV (Dual Flow Valve)
- > McPherson strut **FRONT**
- > Conventional shock absorber **REAR**
- > Single bleed adjuster
- > Height adjustable (approx. 10 mm lower than standard) **FRONT**
- > Height adjustable (approx. 15 mm lower than standard) **REAR**
- > Choose your desired spring rates
- > Recommended spring (70 N/mm) **FRONT**
- > Recommended spring (120 N/mm) **REAR**
- > Use with original top mounts
- > Rebuildable
- > Corrosion salt spray tested (ISO 9227)
- > 2 year limited warranty



## ROAD & TRACK

# BMW 3-SERIES

**YEAR MODEL:** 2004-2013

**CHASSIS CODE:** E90, E91, E92, E93 • **PART NO:** BMS M100



### FEATURES

- > DFV (Dual Flow Valve)
- > McPherson strut **FRONT**
- > Conventional shock absorber **REAR**
- > Single bleed adjuster
- > Height adjustable (approx. 20 mm lower than standard) **FRONT**
- > Height adjustable (approx. 25 mm lower than standard) **REAR**
- > Coil springs (60 N/mm) **FRONT**
- > Coil springs (70 N/mm) **REAR**
- > Use with original top mounts
- > Rebuildable
- > Corrosion salt spray tested (ISO 9227)
- > 2 year limited warranty
- > TÜV approved application



[OHLINS.COM](http://OHLINS.COM)

ROAD & TRACK



# BMW

## 3-SERIES



**YEAR MODEL:** 2012-2018

**CHASSIS CODE:** F30 • **PART NO:** BMS MP00



### FEATURES

- > DFV (Dual Flow Valve)
- > McPherson strut **FRONT**
- > Conventional shock absorber **REAR**
- > Single bleed adjuster
- > Height adjustable (approx. 20 mm lower than standard) **FRONT**
- > Height adjustable (approx. 15 mm lower than standard) **REAR**
- > Coil springs (60 N/mm) **FRONT**
- > Coil springs (160 N/mm) **REAR**
- > Use with original top mounts
- > Rebuildable
- > Corrosion salt spray tested (ISO 9227)
- > 2 year limited warranty
- > Cancellation kit available. For more info see page 107.





ROAD & TRACK

# BMW

## M2 • M2 COMPETITION



**YEAR MODEL:** 2016-2020

**CHASSIS CODE:** F87 • **PART NO:** BMS MR40



### FEATURES

- > DFV (Dual Flow Valve)
- > McPherson strut **FRONT**
- > Conventional shock absorber **REAR**
- > Single bleed adjuster
- > Height adjustable (approx. 10 mm lower than standard)
- > Choose your desired spring rates
- > Recommended spring (90 N/mm) **FRONT**
- > Recommended spring (190 N/mm) **REAR**
- > Use with original top mounts
- > Rebuildable
- > Weight reduction compared to original suspension
- > Corrosion salt spray tested (ISO 9227)
- > 2 year limited warranty
- > TÜV approved application



[OHLINS.COM](http://OHLINS.COM)

ROAD & TRACK

**BMW**

M3



**YEAR MODEL:** 2001-2005

**CHASSIS CODE:** E46 • **PART NO:** BMS M130



#### FEATURES

- > DFV (Dual Flow Valve)
- > McPherson strut **FRONT**
- > Conventional shock absorber **REAR**
- > Single bleed adjuster
- > Height adjustable (approx. 20 mm lower than standard)
- > Coil springs (70 N/mm) **FRONT**
- > Coil springs (110 N/mm) **REAR**
- > Use with original top mounts
- > Rebuildable
- > Corrosion salt spray tested (ISO 9227)
- > 2 year limited warranty
- > TÜV approved application





**ROAD & TRACK**

**BMW**

**M3**



**YEAR MODEL:** 2007-2012

**CHASSIS CODE:** E90, E92 • **PART NO:** BMS MI40



#### FEATURES

- > DFV (Dual Flow Valve)
- > McPherson strut **FRONT**
- > Conventional shock absorber **REAR**
- > Single bleed adjuster
- > Height adjustable (approx. 15 mm lower than standard) **FRONT**
- > Height adjustable (approx. 10 mm lower than standard) **REAR**
- > Coil springs (60 N/mm) **FRONT**
- > Coil springs (120 N/mm) **REAR**
- > Use with original top mounts
- > Rebuildable
- > Weight reduction compared to original suspension
- > Corrosion salt spray tested (ISO 9227)
- > 2 year limited warranty
- > Cancellation kit available. For more info see page 107.
- > TÜV approved application



**OHLINS.COM**

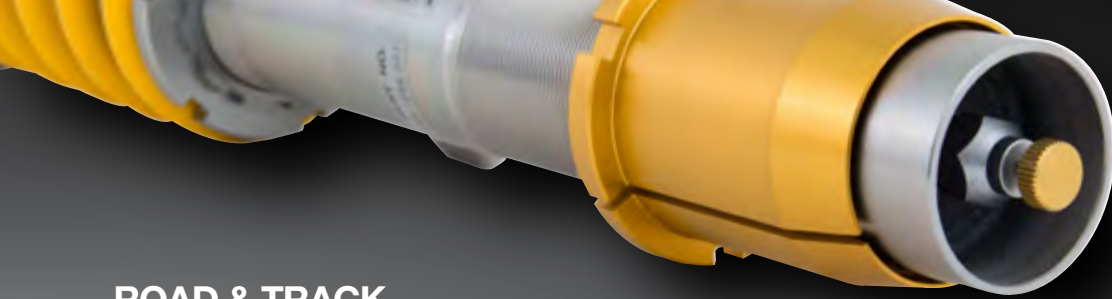

## ROAD & TRACK

# BMW

## M3



**YEAR MODEL:** 2014-2018

**CHASSIS CODE:** F80 • **PART NO:** BMS MR40



### FEATURES

- > DFV (Dual Flow Valve)
- > McPherson strut **FRONT**
- > Conventional shock absorber **REAR**
- > Single bleed adjuster
- > Height adjustable (approx. 10 mm lower than standard)
- > Choose your desired spring rates
- > Recommended spring (90 N/mm) **FRONT**
- > Recommended spring (230 N/mm) **REAR**
- > Use with original top mounts
- > Rebuildable
- > Corrosion salt spray tested (ISO 9227)
- > 2 year limited warranty
- > Cancellation kit available. For more info see page 107.
- > TÜV approved application



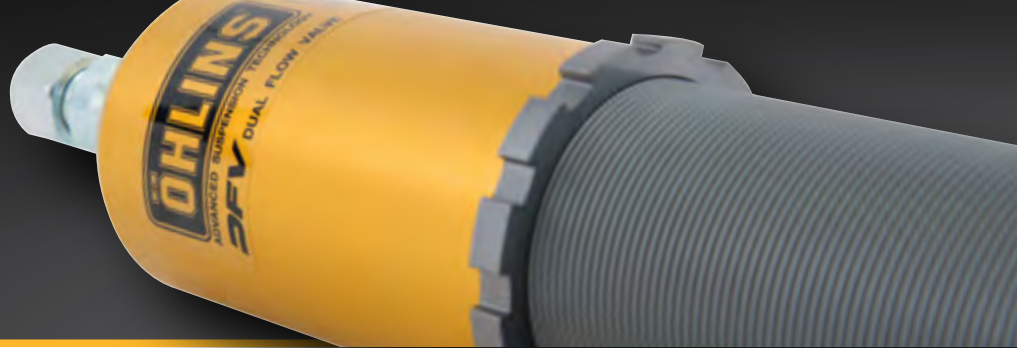

## ROAD & TRACK

# BMW

## M4



**YEAR MODEL:** 2014-2020

**CHASSIS CODE:** F82 • **PART NO:** BMS MR40



### FEATURES

- > DFV (Dual Flow Valve)
- > McPherson strut **FRONT**
- > Conventional shock absorber **REAR**
- > Single bleed adjuster
- > Height adjustable (approx. 10 mm lower than standard)
- > Choose your desired spring rates
- > Recommended spring (90 N/mm) **FRONT**
- > Recommended spring (230 N/mm) **REAR**
- > Use with original top mounts
- > Rebuildable
- > Corrosion salt spray tested (ISO 9227)
- > 2 year limited warranty
- > Cancellation kit available. For more info see page 107.
- > TÜV approved application



[OHLINS.COM](http://OHLINS.COM)

## ROAD & TRACK

# BMW

## Z4

**YEAR MODEL:** 2009-2011

**CHASSIS CODE:** E89 • **PART NO:** BMS MP50



### FEATURES

- > DFV (Dual Flow Valve)
- > McPherson strut **FRONT**
- > Conventional shock absorber **REAR**
- > Single bleed adjuster
- > Height adjustable (approx. 10 mm lower than standard) **FRONT**
- > Height adjustable (approx. 0 mm lower than standard) **REAR**
- > Coil springs (60 N/mm) **FRONT**
- > Coil springs (70 N/mm) **REAR**
- > Use with original top mounts
- > Rebuildable
- > Corrosion salt spray tested (ISO 9227)
- > 2 year limited warranty
- > Cancellation kit available. For more info see page 107.
- > TÜV approved application



ROAD & TRACK

# CHEVROLET CAMARO



**YEAR MODEL:** 2010-2015

**CHASSIS CODE:** 5<sup>TH</sup> GENERATION • **PART NO:** CHS MP00



## FEATURES

- > DFV (Dual Flow Valve)
- > Conventional shock absorber
- > Single bleed adjuster
- > Height adjustable (approx. 20 mm lower than standard) **FRONT**
- > Height adjustable (approx. 15 mm lower than standard) **REAR**
- > Choose your desired spring rates
- > Recommended spring (70 N/mm) **FRONT**
- > Recommended spring (120 N/mm) **REAR**
- > Use with original top mounts
- > Rebuildable
- > Corrosion salt spray tested (ISO 9227)
- > 2 year limited warranty
- > TÜV approved application



[OHLINS.COM](http://OHLINS.COM)

## ROAD & TRACK

# FIAT

## 124 SPIDER



**YEAR MODEL:** 2017-2020

**PART NO:** FIZ MP00 + MAS MP00



### FEATURES

- > DFV (Dual Flow Valve)
- > Conventional shock absorber
- > Single bleed adjuster
- > Height adjustable (approx. 20 mm lower than standard) **FRONT**
- > Height adjustable (approx. 15 mm lower than standard) **REAR**
- > Choose your desired spring rates
- > Recommended spring (100 N/mm) **FRONT**
- > Recommended spring (40 N/mm) **REAR**
- > Use with original top mounts
- > Rebuildable
- > Weight reduction compared to original suspension
- > Corrosion salt spray tested (ISO 9227)
- > 2 year limited warranty





ROAD & TRACK

# FORD

## FOCUS RS

**YEAR MODEL:** 2015-2018

**CHASSIS CODE:** 3<sup>RD</sup> GENERATION • **PART NO:** FOS MS00



### FEATURES

- > DFV (Dual Flow Valve)
- > McPherson strut **FRONT**
- > Conventional shock absorber **REAR**
- > Single bleed adjuster
- > Height adjustable (approx. 15-25 mm lower than standard)
- > Choose your desired spring rates
- > Recommended spring (80 N/mm) **FRONT**
- > Recommended spring (70 N/mm) **REAR**
- > Use with original top mounts
- > Rebuildable
- > Corrosion salt spray tested (ISO 9227)
- > 2 year limited warranty
- > Cancellation kit available. For more info see page 107.



[OHLINS.COM](http://OHLINS.COM)

## ROAD & TRACK



# FORD MUSTANG



**YEAR MODEL:** 2015-2018

**CHASSIS CODE:** 6<sup>TH</sup> GENERATION • **PART NO:** FOS MR00



### FEATURES

- > DFV (Dual Flow Valve)
- > McPherson strut **FRONT**
- > Conventional shock absorber **REAR**
- > Single bleed adjuster
- > Adjustable camber
- > Height adjustable (approx. 25 mm lower than standard)
- > Choose your desired spring rates
- > Recommended spring (90 N/mm) **FRONT**
- > Recommended spring (140 N/mm) **REAR**
- > Use with original top mounts
- > Front shock (McPherson) lower mount has oval mounting hole which offers you the possibility to adjust the camber angle if requested
- > Rebuildable
- > Corrosion salt spray tested (ISO 9227)
- > 2 year limited warranty

**\*NOTE:** Not feasible for vehicle equipped with MagneRide®



ROAD & TRACK

# HONDA

## CIVIC TYPE-R



**YEAR MODEL:** 2006-2011

**CHASSIS CODE:** FD2 • **PART NO:** HOS MI30

### FEATURES

- > DFV (Dual Flow Valve)
- > McPherson strut **FRONT**
- > Conventional shock absorber **REAR**
- > Single bleed adjuster
- > Height adjustable (approx. 15 mm lower than standard) **FRONT**
- > Height adjustable (approx. 30 mm lower than standard) **REAR**
- > Coil springs (80 N/mm) **FRONT**
- > Coil springs (24-65 N/mm Progressive) **REAR**
- > Top mounts included
- > Rebuildable
- > Corrosion salt spray tested (ISO 9227)
- > 2 year limited warranty



[OHLINS.COM](http://OHLINS.COM)

ROAD & TRACK

# HONDA

## CIVIC TYPE-R



**YEAR MODEL:** 2015-2017

**CHASSIS CODE:** FK2 • **PART NO:** HOS MT10



### FEATURES

- > DFV (Dual Flow Valve)
- > McPherson strut **FRONT**
- > Conventional shock absorber **REAR**
- > Single bleed adjuster
- > Height adjustable (approx. 25 mm lower than standard)
- > Choose your desired spring rates
- > Recommended spring (60 N/mm) **FRONT**
- > Recommended spring (50 N/mm) **REAR**
- > Use with original top mounts
- > Rebuildable
- > Corrosion salt spray tested (ISO 9227)
- > 2 year limited warranty
- > Cancellation kit available. For more info see page 107.



ROAD & TRACK



# HONDA

## CIVIC TYPE-R



**YEAR MODEL:** 2017-2020

**CHASSIS CODE:** FK8 • **PART NO:** HOS MT00



### FEATURES

- > DFV (Dual Flow Valve)
- > McPherson strut **FRONT**
- > Conventional shock absorber **REAR**
- > Single bleed adjuster
- > Height adjustable (approx. 15-25 mm lower than standard)
- > Choose your desired spring rates
- > Recommended spring (60 N/mm) **FRONT**
- > Recommended spring (100 N/mm) **REAR**
- > Use with original top mounts
- > Rebuildable
- > Corrosion salt spray tested (ISO 9227)
- > 2 year limited warranty
- > Cancellation kit available. For more info see page 107.
- > TÜV approved application



[OHLINS.COM](http://OHLINS.COM)



ROAD & TRACK

# HONDA

## S2000



**YEAR MODEL:** 1999-2009

**CHASSIS CODE:** AP1, AP2 • **PART NO:** HOS MI21



### FEATURES

- > DFV (Dual Flow Valve)
- > Conventional shock absorber
- > Single bleed adjuster
- > Height adjustable (approx. 25 mm lower than standard)
- > Choose your desired spring rates
- > Recommended spring (110 N/mm) <sup>FRONT</sup>
- > Recommended spring (70 N/mm) <sup>REAR</sup>
- > Top mounts included
- > Rebuildable
- > Weight reduction compared to original suspension
- > Corrosion salt spray tested (ISO 9227)
- > 2 year limited warranty
- > TÜV approved application



ROAD & TRACK

NEW



HYUNDAI

i30 N



YEAR MODEL: 2017-2020

CHASSIS CODE: PD • PART NO: HYS MT00

#### FEATURES

- > DFV (Dual Flow Valve)
- > McPherson strut **FRONT**
- > Conventional shock absorber **REAR**
- > Single bleed adjuster
- > Height adjustable (approx. 10-15 mm lower than standard)
- > Choose your desired spring rates
- > Recommended spring (60 N/mm) **FRONT**
- > Recommended spring (90 N/mm) **REAR**
- > Use with original top mounts
- > Rebuildable
- > Corrosion salt spray tested (ISO 9227)
- > 2 year limited warranty
- > Cancellation kit available. For more info see page 107.



OHLINS.COM



ROAD & TRACK

NEW



LAMBORGHINI

HURACÁN • HURACÁN PERFORMANTE

TTX

**YEAR MODEL: HURACÁN** 2014-2020  
**HURACÁN PERFORMANTE** 2017-2020  
**PART NO:** AUV MT00

#### FEATURES

- > TTX-technology
- > Conventional shock absorber
- > 2-way adjustable
- > Height adjustable (approx. 0 - 10 mm lower than standard)
- > Choose your desired spring rates
- > Recommended spring (160 N/mm) <sup>FRONT</sup>
- > Recommended spring (160 N/mm) <sup>REAR</sup>
- > Rebuildable
- > Weight reduction compared to original suspension: -8 kg
- > Corrosion salt spray tested (ISO 9227)
- > 2 year limited warranty
- > Cancellation kit available. For more info see page 107.



OHLINS.COM



## ROAD & TRACK

# LEXUS

GS 460



**YEAR MODEL:** GS 460 2007-2011  
**CHASSIS CODE:** GS 460 URS190, URS191  
**PART NO:** LES M100

### FEATURES

- > DFV (Dual Flow Valve)
- > Conventional shock absorber
- > Single bleed adjuster
- > Height adjustable (approx. 20 mm lower than standard)
- > Coil springs (100 N/mm) **FRONT**
- > Coil springs (60 N/mm) **REAR**
- > Top mounts included **FRONT**
- > Use with original top mounts **REAR**
- > Rebuildable
- > Weight reduction compared to original suspension
- > Corrosion salt spray tested (ISO 9227)
- > 2 year limited warranty



[OHLINS.COM](http://OHLINS.COM)



ROAD & TRACK

# LEXUS

IS 250 • IS 350 • IS-F



**YEAR MODEL:** IS 250 / IS 350 2005-2013 • IS-F 2005-2013

**CHASSIS CODE:** IS 250 GSE20 • IS 350 GSE21 • IS-F USE20R

**PART NO:** LES M100



## FEATURES

- > DFV (Dual Flow Valve)
- > Conventional shock absorber
- > Single bleed adjuster
- > Height adjustable (approx. 20 mm lower than standard)
- > Coil springs (100 N/mm) <sup>FRONT</sup>
- > Coil springs (60 N/mm) <sup>REAR</sup>
- > Top mounts included <sup>FRONT</sup>
- > Use with original top mounts <sup>REAR</sup>
- > Rebuildable
- > Weight reduction compared to original suspension
- > Corrosion salt spray tested (ISO 9227)
- > 2 year limited warranty



ROAD & TRACK



# LOTUS

ELISE • EXIGE

STX

**YEAR MODEL:** ELISE 2001-2011 • EXIGE 2006-2011

**PART NO:** LOV 1-4D00



## FEATURES

- > 1-way compression adjuster
- > 1-way rebound adjuster (shaft bleed) also have a temperature compensating function
- > Height adjustable (spring preload)
- > Coil springs (35 N/mm) <sup>FRONT</sup>
- > Coil springs (60 N/mm) <sup>REAR</sup>
- > Rebuildable
- > Weight reduction compared to original suspension



OHLINS.COM

## ROAD & TRACK

# MAZDA

## MX-5



**YEAR MODEL:** 1989-2005

**CHASSIS CODE:** NA/NB • **PART NO:** MAS MI20



### FEATURES

- > DFV (Dual Flow Valve)
- > Conventional shock absorber
- > Single bleed adjuster
- > Height adjustable (approx. 20 mm lower than standard)
- > Coil springs (80 N/mm) <sup>FRONT</sup>
- > Coil springs (60 N/mm) <sup>REAR</sup>
- > Top mounts included
- > Rebuildable
- > Weight reduction compared to original suspension
- > Corrosion salt spray tested (ISO 9227)
- > 2 year limited warranty
- > TUV approved application



## ROAD & TRACK



# MAZDA

MX-5



**YEAR MODEL:** 2005-2015

**CHASSIS CODE:** NC • **PART NO:** MAS MI30



### FEATURES

- > DFV (Dual Flow Valve)
- > Conventional shock absorber
- > Single bleed adjuster
- > Height adjustable (approx. 35 mm lower than standard)
- > Coil springs (70 N/mm) **FRONT**
- > Coil springs (40 N/mm) **REAR**
- > Top mounts included **FRONT**
- > Use with original top mounts **REAR**
- > Rebuildable
- > Weight reduction compared to original suspension
- > Corrosion salt spray tested (ISO 9227)
- > 2 year limited warranty
- > TÜV approved application



[OHLINS.COM](http://OHLINS.COM)

ROAD & TRACK



# MAZDA

MX-5



**YEAR MODEL:** 2016-2020

**CHASSIS CODE:** ND/RF • **PART NO:** MAS MP00



## FEATURES

- > DFV (Dual Flow Valve)
- > Conventional shock absorber
- > Single bleed adjuster
- > Height adjustable (approx. 20 mm lower than standard) **FRONT**
- > Height adjustable (approx. 15 mm lower than standard) **FRONT**
- > Choose your desired spring rates
- > Recommended spring (100 N/mm) **FRONT**
- > Recommended spring (40 N/mm) **REAR**
- > Use with original top mounts
- > Rebuildable
- > Weight reduction compared to original suspension
- > Corrosion salt spray tested (ISO 9227)
- > 2 year limited warranty
- > TÜV approved application



ROAD & TRACK

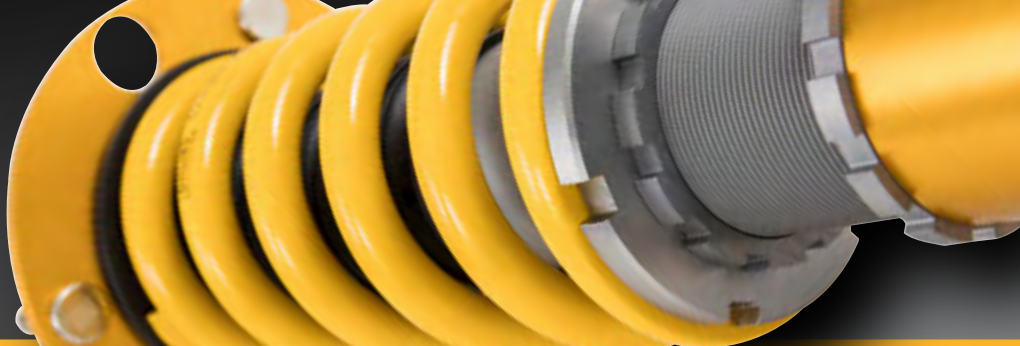

# MAZDA

RX-7



**YEAR MODEL:** 1991-2002

**CHASSIS CODE:** FD3S • **PART NO:** MAS MI10



## FEATURES

- > DFV (Dual Flow Valve)
- > Conventional shock absorber
- > Single bleed adjuster
- > Height adjustable (approx. 25 mm lower than standard) **FRONT**
- > Height adjustable (approx. 20 mm lower than standard) **REAR**
- > Coil springs (110 N/mm)
- > Top mounts included
- > Rebuildable
- > Weight reduction compared to original suspension
- > Corrosion salt spray tested (ISO 9227)
- > 2 year limited warranty



OHLINS.COM

ROAD & TRACK



# MAZDA

RX-8



**YEAR MODEL:** 2003-2008

**CHASSIS CODE:** SE3P • **PART NO:** MAS M100



## FEATURES

- > DFV (Dual Flow Valve)
- > Conventional shock absorber
- > Single bleed adjuster
- > Height adjustable (approx. 35 mm lower than standard)
- > Coil springs (80 N/mm) **FRONT**
- > Coil springs (40 N/mm) **REAR**
- > Top mounts included **FRONT**
- > Use with original top mounts **REAR**
- > Rebuildable
- > Weight reduction compared to original suspension: -12 kg
- > Corrosion salt spray tested (ISO 9227)
- > 2 year limited warranty





ROAD & TRACK

# MERCEDES-BENZ

G350 • G400 • G500 • G550 • G63 • G65

**STX**

**YEAR MODEL:** 1979-2017

**PART NO:** MEV 1-4S46



## FEATURES

- > STX-technology
- > Developed specially for Mercedes Benz G-Wagen
- > 46 mm piston for best performance (comfort and chassi control)
- > Remote reservoir
- > 2-way adjustable (Compression and rebound damping forces)
- > To be used with OE-springs
- > Possible to update for extended wheel travel
- > Rebuildable
- > Weight reduction compared to original suspension



**OHLINS.COM**

ROAD & TRACK

# MINI COOPER S



**YEAR MODEL:** 2000-2006

**CHASSIS CODE:** R50/R53 • **PART NO:** BMS MI10



## FEATURES

- > DFV (Dual Flow Valve)
- > McPherson strut **FRONT**
- > Conventional shock absorber **REAR**
- > Single bleed adjuster
- > Height adjustable (approx. 20 mm lower than standard) **FRONT**
- > Height adjustable (approx. 25 mm lower than standard) **REAR**
- > Coil springs (60 N/mm) **FRONT**
- > Coil springs (50 N/mm) **REAR**
- > Top mounts included **FRONT**
- > Use with original top mounts **REAR**
- > Rebuildable
- > Corrosion salt spray tested (ISO 9227)
- > 2 year limited warranty
- > TÜV approved application



ROAD & TRACK



# MINI COOPER



**YEAR MODEL:** 2006-2013

**CHASSIS CODE:** R56 • **PART NO:** BMS MI20



## FEATURES

- > DFV (Dual Flow Valve)
- > McPherson strut **FRONT**
- > Conventional shock absorber **REAR**
- > Single bleed adjuster
- > Height adjustable (approx. 18 mm lower than standard)
- > Coil springs (70 N/mm) **FRONT**
- > Coil springs (50 N/mm) **REAR**
- > Use with original top mounts
- > Rebuildable
- > Corrosion salt spray tested (ISO 9227)
- > 2 year limited warranty
- > TÜV approved application



[OHLINS.COM](http://OHLINS.COM)

ROAD & TRACK

# MITSUBISHI

## LANCER EVO IV-VI



**YEAR MODEL:** 1996-2001

**CHASSIS CODE:** CN9A, CP9A • **PART NO:** MIZ M100 + MIS M101



### FEATURES

- > DFV (Dual Flow Valve)
- > McPherson strut **FRONT**
- > Conventional shock absorber **REAR**
- > Single bleed adjuster
- > Height adjustable (approx. 15 mm lower than standard)
- > Choose your desired spring rates
- > Recommended spring (100 N/mm) **FRONT**
- > Recommended spring (80 N/mm) **REAR**
- > Top mounts with camber adjustments **FRONT**
- > Top mounts included
- > Rebuildable
- > Corrosion salt spray tested (ISO 9227)
- > 2 year limited warranty



ROAD & TRACK

# MITSUBISHI

## LANCER EVO VII-IX



**YEAR MODEL:** 2001-2008

**CHASSIS CODE:** CT9A • **PART NO:** MIS MI01



### FEATURES

- > DFV (Dual Flow Valve)
- > McPherson strut **FRONT**
- > Conventional shock absorber **REAR**
- > Single bleed adjuster
- > Height adjustable (approx. 35 mm lower than standard) **FRONT**
- > Height adjustable (approx. 30 mm lower than standard) **REAR**
- > Choose your desired spring rates
- > Recommended spring (100 N/mm) **FRONT**
- > Recommended spring (80 N/mm) **REAR**
- > Top mounts with camber adjustments **FRONT**
- > Top mounts included
- > Rebuildable
- > Corrosion salt spray tested (ISO 9227)
- > 2 year limited warranty
- > TÜV approved application



OHLINS.COM

ROAD & TRACK

# MITSUBISHI

## LANCER EVO X

**YEAR MODEL:** 2007-2016

**CHASSIS CODE:** CZ4A • **PART NO:** MIS MI10



### FEATURES

- > DFV (Dual Flow Valve)
- > McPherson strut **FRONT**
- > Conventional shock absorber **REAR**
- > Single bleed adjuster
- > Height adjustable (approx. 25 mm lower than standard)
- > Coil springs (100 N/mm) **FRONT**
- > Coil springs (70 N/mm) **REAR**
- > Top mounts with camber adjustments **FRONT**
- > Top mounts included
- > Rebuildable
- > Corrosion salt spray tested (ISO 9227)
- > 2 year limited warranty
- > TÜV approved application

**DFV**



ROAD & TRACK

# NISSAN

## 350Z



**YEAR MODEL:** 2002-2009

**CHASSIS CODE:** Z33 • **PART NO:** NIS M100



### FEATURES

- > DFV (Dual Flow Valve)
- > Conventional shock absorber
- > Single bleed adjuster
- > Height adjustable (approx. 20 mm lower than standard)
- > Coil springs (100 N/mm) **FRONT**
- > Coil springs (70 N/mm) **REAR**
- > Top mounts (included)
- > Rebuildable
- > Weight reduction compared to original suspension
- > Corrosion salt spray tested (ISO 9227)
- > 2 year limited warranty



[OHLINS.COM](http://OHLINS.COM)

ROAD & TRACK

# NISSAN

## SKYLINE GT-R



**YEAR MODEL:** 1993-2002

**CHASSIS CODE:** BCNR33, BNR34 • **PART NO:** NIS MI10



### FEATURES

- > DFV (Dual Flow Valve)
- > Conventional shock absorber
- > Single bleed adjuster
- > Height adjustable (approx. 30 mm lower than standard)
- > Coil springs (90 N/mm) **FRONT**
- > Coil springs (80 N/mm) **REAR**
- > Top mounts (included)
- > Rebuildable
- > Weight reduction compared to original suspension
- > Corrosion salt spray tested (ISO 9227)
- > 2 year limited warranty
- > TÜV approved application



ROAD & TRACK

# NISSAN

## GT-R



**YEAR MODEL:** 2007-2020

**CHASSIS CODE:** R35 • **PART NO:** NIZ MI30



### FEATURES

- > DFV (Dual Flow Valve)
- > Conventional shock absorber
- > Single bleed adjuster
- > Height adjustable (approx. 10 mm lower than standard)
- > Coil springs (160 N/mm) **FRONT**
- > Coil springs (90 N/mm) **REAR**
- > Top mounts (included) **FRONT**
- > Use with original top mounts **REAR**
- > Rebuildable
- > Weight reduction compared to original suspension
- > Corrosion salt spray tested (ISO 9227)
- > 2 year limited warranty
- > Cancellation kit available. For more info see page 107.
- > TÜV approved application



OH LINS.COM

ROAD & TRACK



# OPEL / VAUXHALL

SPEEDSTER • VX220

STX

**YEAR MODEL:** 2000-2005

**PART NO:** OPV 1-4E00



## FEATURES

- > 1-way compression adjuster
- > 1-way rebound adjuster (shaft bleed) also have a temperature compensating function
- > Height adjustable (spring preload)
- > Coil springs (62 N/mm) **FRONT**
- > Coil springs (85 N/mm) **REAR**
- > Rebuildable
- > Weight reduction compared to original suspension



ROAD & TRACK

NEW

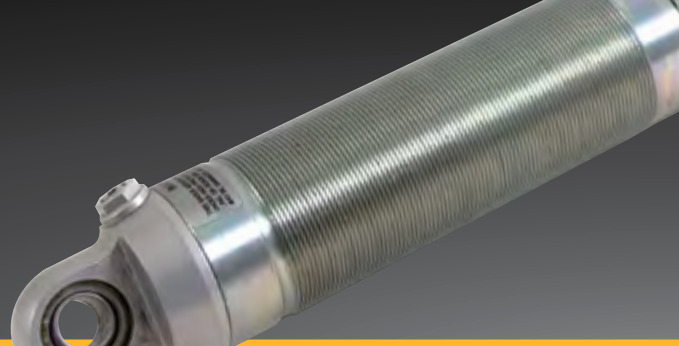

# PORSCHE 911

STX

**YEAR MODEL:** 1964-1989

**PART NO:** POR 5L00, POR 6L00

## FEATURES

- > STX-technology
- > Insert for McPherson-strut, original Bilstein 40 mm outer tube **FRONT**
- > Conventional shock absorber **REAR**
- > Recommended spring torsion bar, in the upper stiffer segment
- > Rebuildable
- > 2 year limited warranty



OHLINS.COM





**ROAD & TRACK**

# PORSCHE 718

BOXSTER • BOXSTER S • BOXSTER GTS



**YEAR MODEL:** 2016-2020

**CHASSIS CODE:** 982 • **PART NO:** POS MP80



## FEATURES

- > DFV (Dual Flow Valve)
- > McPherson strut
- > Single bleed adjuster
- > Height adjustable (approx. 20 mm lower than standard)
- > Choose your desired spring rates
- > Recommended spring (70 N/mm) **FRONT**
- > Recommended spring (80 N/mm) **REAR**
- > Use with original top mounts
- > Rebuildable
- > Corrosion salt spray tested (ISO 9227)
- > 2 year limited warranty



**OHLINS.COM**



ROAD & TRACK

# PORSCHE 718

CAYMAN • CAYMAN S • CAYMAN GTS



**YEAR MODEL:** 2016-2020

**CHASSIS CODE:** 982 • **PART NO:** POS MP80

## FEATURES

- > DFV (Dual Flow Valve)
- > McPherson strut
- > Single bleed adjuster
- > Height adjustable (approx. 20 mm lower than standard)
- > Choose your desired spring rates
- > Recommended spring (70 N/mm) **FRONT**
- > Recommended spring (80 N/mm) **REAR**
- > Use with original top mounts
- > Rebuildable
- > Corrosion salt spray tested (ISO 9227)
- > 2 year limited warranty



ROAD & TRACK



# PORSCHE 981

BOXSTER • BOXSTER S • BOXSTER GTS



**YEAR MODEL:** 2012-2016

**CHASSIS CODE:** 981 • **PART NO:** POS MP80



## FEATURES

- > DFV (Dual Flow Valve)
- > McPherson strut
- > Single bleed adjuster
- > Height adjustable (approx. 20 mm lower than standard)
- > Choose your desired spring rates
- > Recommended spring (70 N/mm) **FRONT**
- > Recommended spring (80 N/mm) **REAR**
- > Use with original top mounts
- > Rebuildable
- > Corrosion salt spray tested (ISO 9227)
- > 2 year limited warranty
- > Cancellation kit available. For more info see page 107.



OHLINS.COM

ROAD & TRACK

# PORSCHE 981

CAYMAN • CAYMAN S • CAYMAN GTS



**YEAR MODEL:** 2012-2016

**CHASSIS CODE:** 981 • **PART NO:** POS MP80



## FEATURES

- > DFV (Dual Flow Valve)
- > McPherson strut
- > Single bleed adjuster
- > Height adjustable (approx. 20 mm lower than standard)
- > Choose your desired spring rates
- > Recommended spring (70 N/mm) **FRONT**
- > Recommended spring (80 N/mm) **REAR**
- > Use with original top mounts
- > Rebuildable
- > Corrosion salt spray tested (ISO 9227)
- > 2 year limited warranty
- > Cancellation kit available. For more info see page 107.



ROAD & TRACK

# PORSCHE 981

CAYMAN GT4 • CAYMAN GT4 CLUB SPORT



**YEAR MODEL:** 2016-2017

**CHASSIS CODE:** 981 • **PART NO:** POF 5R00, POF 6R10



## FEATURES

- > TTX-technology
- > McPherson strut
- > 2-way adjustable
- > Height adjustable (approx. 20 mm lower than standard)
- > Choose your desired spring rates
- > Recommended spring (100 N/mm) **FRONT**
- > Recommended spring (120 N/mm) **REAR**
- > Use with original top mounts
- > Rebuildable
- > Corrosion salt spray tested (ISO 9227)
- > 2 year limited warranty
- > Cancellation kit available. For more info see page 107.



OHLINS.COM

ROAD & TRACK

# PORSCHE 981

## CAYMAN GT4



**YEAR MODEL:** 2016-2017

**CHASSIS CODE:** 981 • **PART NO:** POZ MR90



### FEATURES

- > DFV (Dual Flow Valve)
- > McPherson strut
- > Single bleed adjuster
- > Height adjustable (approx. 20 mm lower than standard)
- > Choose your desired spring rates
- > Recommended spring (80 N/mm) **FRONT**
- > Recommended spring (90 N/mm) **REAR**
- > Use with original top mounts
- > Rebuildable
- > 2 year limited warranty
- > Cancellation kit available. For more info see page 107.



ROAD & TRACK

# PORSCHE 986

BOXSTER • BOXSTER S



**YEAR MODEL:** 1996-2004

**CHASSIS CODE:** 986 • **PART NO:** POS MR80



## FEATURES

- > DFV (Dual Flow Valve)
- > McPherson strut
- > Single bleed adjuster
- > Height adjustable (approx. 20 mm lower than standard)
- > Coil springs (70 N/mm) **FRONT**
- > Coil springs (80 N/mm) **REAR**
- > Use with original top mounts
- > Rebuildable
- > Corrosion salt spray tested (ISO 9227)
- > 2 year limited warranty



[OHLINS.COM](http://OHLINS.COM)



ROAD & TRACK

# PORSCHE 987

BOXSTER • BOXSTER S



**YEAR MODEL:** 2005-2012

**CHASSIS CODE:** 987 • **PART NO:** POS MR80

## FEATURES

- > DFV (Dual Flow Valve)
- > McPherson strut
- > Single bleed adjuster
- > Height adjustable (approx. 20 mm lower than standard)
- > Coil springs (70 N/mm) **FRONT**
- > Coil springs (80 N/mm) **REAR**
- > Use with original top mounts
- > Rebuildable
- > Corrosion salt spray tested (ISO 9227)
- > 2 year limited warranty
- > Cancellation kit available. For more info see page 107.

ROAD & TRACK



# PORSCHE 987

CAYMAN • CAYMAN S • CAYMAN R



**YEAR MODEL:** 2005-2012

**CHASSIS CODE:** 987 • **PART NO:** POS MR80



## FEATURES

- > DFV (Dual Flow Valve)
- > McPherson strut
- > Single bleed adjuster
- > Height adjustable (approx. 20 mm lower than standard)
- > Coil springs (70 N/mm) **FRONT**
- > Coil springs (80 N/mm) **REAR**
- > Use with original top mounts
- > Rebuildable
- > Corrosion salt spray tested (ISO 9227)
- > 2 year limited warranty
- > Cancellation kit available. For more info see page 107.



OHLINS.COM



ROAD & TRACK

# PORSCHE 996

## CARRERA • TARGA

SEE ALL AVAILABLE MODELS ON PAGE 110



**YEAR MODEL:** 1999-2004

**CHASSIS CODE:** 996 • **PART NO:** POZ MI00

### FEATURES

- > DFV (Dual Flow Valve)
- > McPherson strut **FRONT**
- > Conventional shock absorber **REAR**
- > Single bleed adjuster
- > Height adjustable (approx. 20 mm lower than standard)
- > Coil springs (60 N/mm) **FRONT**
- > Coil springs (120 N/mm) **REAR**
- > Use with original top mounts
- > Rebuildable
- > Corrosion salt spray tested (ISO 9227)
- > 2 year limited warranty
- > TÜV approved application



ROAD & TRACK



# PORSCHE 996

## CARRERA 4 • CARRERA 4S

SEE ALL AVAILABLE MODELS ON PAGE 110



**YEAR MODEL:** 1999-2005

**CHASSIS CODE:** 996 • **PART NO:** POZ MN02

### FEATURES

- > DFV (Dual Flow Valve)
- > McPherson strut **FRONT**
- > Conventional shock absorber **REAR**
- > Single bleed adjuster
- > Height adjustable (approx. 20 mm lower than standard)
- > Coil springs (70 N/mm) **FRONT**
- > Coil springs (120 N/mm) **REAR**
- > Use with original top mounts
- > Rebuildable
- > Corrosion salt spray tested (ISO 9227)
- > 2 year limited warranty
- > TÜV approved application

[OHLINS.COM](http://OHLINS.COM)

ROAD & TRACK

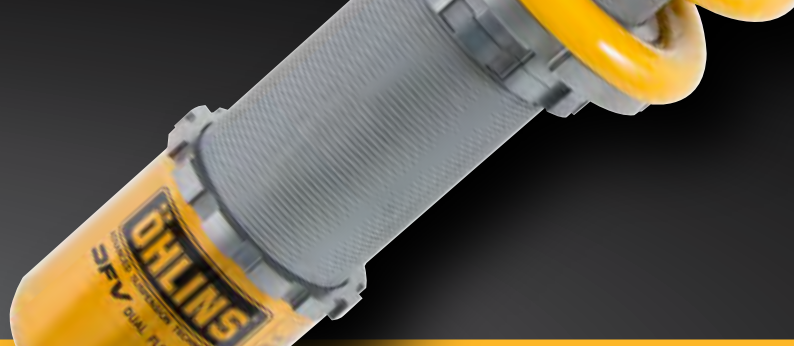

# PORSCHE 996

## TURBO • TURBO S

SEE ALL AVAILABLE MODELS ON PAGE 110



**YEAR MODEL:** 2001-2005

**CHASSIS CODE:** 996 • **PART NO:** POZ MN02

### FEATURES

- > DFV (Dual Flow Valve)
- > McPherson strut **FRONT**
- > Conventional shock absorber **REAR**
- > Single bleed adjuster
- > Height adjustable (approx. 20 mm lower than standard)
- > Coil springs (70 N/mm) **FRONT**
- > Coil springs (120 N/mm) **REAR**
- > Use with original top mounts
- > Rebuildable
- > Corrosion salt spray tested (ISO 9227)
- > 2 year limited warranty
- > TÜV approved application



ROAD & TRACK

# PORSCHE 996 GT2



**YEAR MODEL:** 1999-2005

**CHASSIS CODE:** 996 • **PART NO:** POS MI10

## FEATURES

- > DFV (Dual Flow Valve)
- > McPherson strut **FRONT**
- > Conventional shock absorber **REAR**
- > Single bleed adjuster
- > Height adjustable (approx. 20 mm lower than standard)
- > Coil springs (70 N/mm) **FRONT**
- > Coil springs (140 N/mm) **REAR**
- > Use with original top mounts
- > Rebuildable
- > Corrosion salt spray tested (ISO 9227)
- > 2 year limited warranty
- > TÜV approved application



[OHLINS.COM](http://OHLINS.COM)

ROAD & TRACK



# PORSCHE 996

GT3 • GT3 RS

SEE ALL AVAILABLE MODELS ON PAGE 110



**YEAR MODEL:** 1999-2005

**CHASSIS CODE:** 996 • **PART NO:** POS MI10



## FEATURES

- > DFV (Dual Flow Valve)
- > McPherson strut **FRONT**
- > Conventional shock absorber **REAR**
- > Single bleed adjuster
- > Height adjustable (approx. 20 mm lower than standard)
- > Coil springs (70 N/mm) **FRONT**
- > Coil springs (140 N/mm) **REAR**
- > Use with original top mounts
- > Rebuildable
- > Corrosion salt spray tested (ISO 9227)
- > 2 year limited warranty
- > TÜV approved application



ROAD & TRACK

# PORSCHE 997

## CARRERA • CARRERA S

SEE ALL AVAILABLE MODELS ON PAGE 110



**YEAR MODEL:** 2005-2015

**CHASSIS CODE:** 997 • **PART NO:** POS MI20

### FEATURES

- > DFV (Dual Flow Valve)
- > McPherson strut **FRONT**
- > Conventional shock absorber **REAR**
- > Single bleed adjuster
- > Height adjustable (approx. 20 mm lower than standard)
- > Coil springs (60 N/mm) **FRONT**
- > Coil springs (120 N/mm) **REAR**
- > Use with original top mounts
- > Rebuildable
- > Corrosion salt spray tested (ISO 9227)
- > 2 year limited warranty
- > Cancellation kit available. For more info see page 107.
- > TÜV approved application



OHLINS.COM



ROAD & TRACK

# PORSCHE 997

## CARRERA 4 • TARGA 4

SEE ALL AVAILABLE MODELS ON PAGE 110

**YEAR MODEL:** 2005-2012

**CHASSIS CODE:** 997 • **PART NO:** POZ MN05

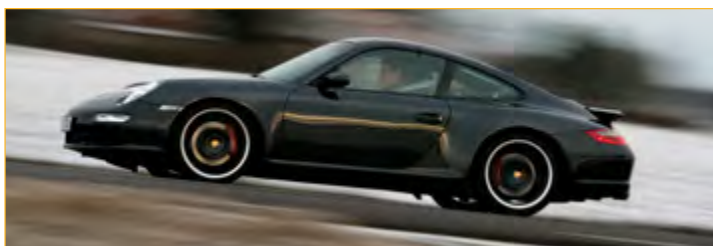

### FEATURES

- > DFV (Dual Flow Valve)
- > McPherson strut **FRONT**
- > Conventional shock absorber **REAR**
- > Single bleed adjuster
- > Height adjustable (approx. 35 mm lower than standard)
- > Coil springs (70 N/mm) **FRONT**
- > Coil springs (120 N/mm) **REAR**
- > Use with original top mounts
- > Rebuildable
- > Corrosion salt spray tested (ISO 9227)
- > 2 year limited warranty
- > Cancellation kit available. For more info see page 107.
- > TÜV approved application



## ROAD & TRACK

# PORSCHE 997

## TURBO • TURBO S

SEE ALL AVAILABLE MODELS ON PAGE 110

**YEAR MODEL:** 2005-2012

**CHASSIS CODE:** 997 • **PART NO:** POZ MN05



### FEATURES

- > DFV (Dual Flow Valve)
- > McPherson strut **FRONT**
- > Conventional shock absorber **REAR**
- > Single bleed adjuster
- > Height adjustable (approx. 35 mm lower than standard)
- > Coil springs (70 N/mm) **FRONT**
- > Coil springs (120 N/mm) **REAR**
- > Use with original top mounts
- > Rebuildable
- > Corrosion salt spray tested (ISO 9227)
- > 2 year limited warranty
- > Cancellation kit available. For more info see page 107.
- > TÜV approved application



**OHLINS.COM**

ROAD & TRACK

# PORSCHE 997

GT2 • GT2 RS



**YEAR MODEL:** 2007-2011

**CHASSIS CODE:** 997 • **PART NO:** POZ MN04

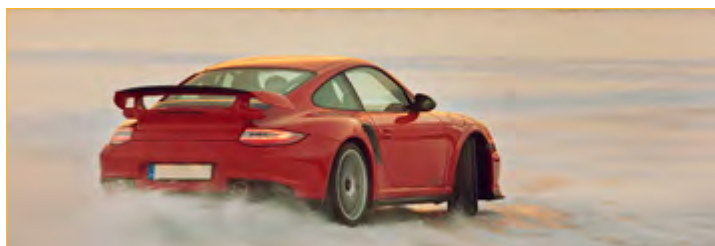

## FEATURES

- > DFV (Dual Flow Valve)
- > McPherson strut **FRONT**
- > Conventional shock absorber **REAR**
- > Single bleed adjuster
- > Height adjustable (approx. 5 mm lower than standard)
- > Coil springs (90 N/mm) **FRONT**
- > Coil springs (140 N/mm) **REAR**
- > Use with original top mounts
- > Rebuildable
- > Corrosion salt spray tested (ISO 9227)
- > 2 year limited warranty
- > Cancellation kit available. For more info see page 107.
- > TÜV approved application



ROAD & TRACK

# PORSCHE 997

GT3 • GT3 RS • GT3 RS 4.0



**YEAR MODEL:** 2007-2011

**CHASSIS CODE:** 997 • **PART NO:** POZ MN04



## FEATURES

- > DFV (Dual Flow Valve)
- > McPherson strut **FRONT**
- > Conventional shock absorber **REAR**
- > Single bleed adjuster
- > Height adjustable (approx. 5 mm lower than standard)
- > Coil springs (90 N/mm) **FRONT**
- > Coil springs (140 N/mm) **REAR**
- > Use with original top mounts
- > Rebuildable
- > Corrosion salt spray tested (ISO 9227)
- > 2 year limited warranty
- > Cancellation kit available. For more info see page 107.
- > TÜV approved application



OHLINS.COM



ROAD & TRACK

# PORSCHE 997

GT3 RS



**YEAR MODEL:** 2007-2011

**CHASSIS CODE:** 997 • **PART NO:** POF 5Q00, POF 6N01



## FEATURES

- > TTX-technology
- > McPherson strut **FRONT**
- > Conventional shock absorber **REAR**
- > 2-way adjustable
- > Height adjustable (approx. 20 mm lower than standard)
- > Coil springs (120 N/mm) **FRONT**
- > Coil springs (170 N/mm) **REAR**
- > Use with original top mounts
- > Rebuildable
- > 2 year limited warranty
- > Cancellation kit available. For more info see page 107.





## ROAD & TRACK

# PORSCHE 991

CARRERA • CARRERA S



**YEAR MODEL:** 2011-2019

**CHASSIS CODE:** 991.1, 991.2 • **PART NO:** POS MP70



### FEATURES

- > DFV (Dual Flow Valve)
- > McPherson strut **FRONT**
- > Conventional shock absorber **REAR**
- > Single bleed adjuster
- > Height adjustable (approx. 10 mm lower than standard)
- > Choose your desired spring rates
- > Recommended spring (70 N/mm) **FRONT**
- > Recommended spring (120 N/mm) **REAR**
- > Use with original top mounts
- > Rebuildable
- > Corrosion salt spray tested (ISO 9227)
- > 2 year limited warranty
- > Cancellation kit available. For more info see page 107.



[OHLINS.COM](http://OHLINS.COM)



ROAD & TRACK

# PORSCHE 991

## CARRERA 4 GTS • TARGA 4

SEE ALL AVAILABLE MODELS ON PAGE 110

**YEAR MODEL:** 2013-2019

**CHASSIS CODE:** 991.1, 991.2 • **PART NO:** POS MS00

### FEATURES

- > DFV (Dual Flow Valve)
- > McPherson strut **FRONT**
- > Conventional shock absorber **REAR**
- > Single bleed adjuster
- > Height adjustable (approx. 10-20 mm lower than standard)
- > Choose your desired spring rates
- > Recommended spring (70 N/mm) **FRONT**
- > Recommended spring (140 N/mm) **REAR**
- > Use with original top mounts
- > Rebuildable
- > Corrosion salt spray tested (ISO 9227)
- > 2 year limited warranty
- > Cancellation kit available. For more info see page 107.





ROAD & TRACK

# PORSCHE 991

## TURBO • TURBO S

SEE ALL AVAILABLE MODELS ON PAGE 110



**YEAR MODEL:** 2013-2019

**CHASSIS CODE:** 991.1, 991.2 • **PART NO:** POS MS00



### FEATURES

- > DFV (Dual Flow Valve)
- > McPherson strut **FRONT**
- > Conventional shock absorber **REAR**
- > Single bleed adjuster
- > Height adjustable (approx. 10-20 mm lower than standard)
- > Choose your desired spring rates
- > Recommended spring (70 N/mm) **FRONT**
- > Recommended spring (140 N/mm) **REAR**
- > Use with original top mounts
- > Rebuildable
- > Corrosion salt spray tested (ISO 9227)
- > 2 year limited warranty
- > Cancellation kit available. For more info see page 107.



OHLINS.COM



## ROAD & TRACK

# PORSCHE 991

GT3 • GT3 RS



**YEAR MODEL:** 2013-2020

**CHASSIS CODE:** 991.1, 991.2 • **PART NO:** POF 5R00, POF 6R00



### FEATURES

- > TTX-technology
- > McPherson strut **FRONT**
- > Conventional shock absorber **REAR**
- > 2-way adjustable
- > Height adjustable (approx. 20 mm lower than standard)
- > Choose your desired spring rates
- > Recommended spring (100/120 N/mm) **FRONT**
- > Recommended spring (200 N/mm) **REAR**
- > Use with original top mounts
- > Rebuildable
- > 2 year limited warranty
- > Cancellation kit available. For more info see page 107.
- > TÜV approved application



ROAD & TRACK

# RENAULT

MÉGANE R.S. TROPHY 275 •  
MÉGANE R.S. 275 TROPHY-R



This kit is available as an upgrade option through the Renault dealer network.

**YEAR MODEL:** 2014-2017

**RENAULT PART NO:** 8201603148



## FEATURES

- > DFV (Dual Flow Valve)
- > McPherson strut **FRONT**
- > Conventional Shock Absorber **REAR**
- > Single bleed adjuster
- > Rebuildable
- > Corrosion salt spray tested (ISO 9227)
- > 2 year limited warranty



OHLINS.COM



ROAD & TRACK

# SEAT

## LEON • TOLEDO

SEE ALL AVAILABLE MODELS ON PAGE 110



**YEAR MODEL:** LEON 2005-2012, TOLEDO 2004-2009  
**CHASSIS CODE:** LEON MK2, TYPE 1P, TOLEDO MK3, 5P  
**PART NO:** VWS MT10

### FEATURES

- > DFV (Dual Flow Valve)
- > McPherson strut **FRONT**
- > Conventional shock absorber **REAR**
- > Single bleed adjuster
- > Height adjustable (approx. 20 mm lower than standard)
- > Choose your desired spring rates
- > Recommended spring (70 N/mm) **FRONT**
- > Recommended spring, Leon (70 N/mm) **REAR**
- > Recommended spring, Toledo (80 N/mm) **REAR**
- > Use with original top mounts
- > Rebuildable
- > Weight reduction compared to original suspension: -10 kg
- > Corrosion salt spray tested (ISO 9227)
- > 2 year limited warranty
- > Cancellation kit available. For more info see page 107.



## ROAD & TRACK

# SEAT

## LEON

SEE ALL AVAILABLE MODELS ON PAGE 110

**YEAR MODEL:** 2012-2020

**CHASSIS CODE:** MK3, TYPE 5F • **PART NO:** VWS MT21



### FEATURES

- > DFV (Dual Flow Valve)
- > McPherson strut **FRONT**
- > Conventional shock absorber **REAR**
- > Single bleed adjuster
- > Height adjustable (approx. 15-20 mm lower than standard)
- > Choose your desired spring rates
- > Recommended spring (70 N/mm) **FRONT**
- > Recommended spring FWD (70 N/mm), 4WD/ST (80 N/mm) **REAR**
- > Use with original top mounts
- > Rebuildable
- > Weight reduction compared to original suspension: -10 kg
- > Corrosion salt spray tested (ISO 9227)
- > 2 year limited warranty
- > Cancellation kit available. For more info see page 107.



[OHLINS.COM](http://OHLINS.COM)



ROAD & TRACK

**SKODA**

OCTAVIA • OCTAVIA RS



**YEAR MODEL: OCTAVIA • OCTAVIA RS 2005-2013**

**CHASSIS CODE: 1Z • PART NO: VWS MT10**



#### FEATURES

- > DFV (Dual Flow Valve)
- > McPherson strut **FRONT**
- > Conventional shock absorber **REAR**
- > Single bleed adjuster
- > Height adjustable (approx. 20 mm lower than standard)
- > Choose your desired spring rates
- > Recommended spring (70 N/mm) **FRONT**
- > Recommended spring FWD (70 N/mm), 4WD/Estate (80 N/mm) **REAR**
- > Use with original top mounts
- > Rebuildable
- > Weight reduction compared to original suspension: -10 kg
- > Corrosion salt spray tested (ISO 9227)
- > 2 year limited warranty
- > Cancellation kit available. For more info see page 107.





**ROAD & TRACK**

**SKODA**

OCTAVIA • OCTAVIA RS



**YEAR MODEL: OCTAVIA • OCTAVIA RS 2013-2020**

**CHASSIS CODE: MK3, TYPE 5E • PART NO: VWS MT21**



### FEATURES

- > DFV (Dual Flow Valve)
- > McPherson strut **FRONT**
- > Conventional shock absorber **REAR**
- > Single bleed adjuster
- > Height adjustable (approx. 15 mm lower than standard)
- > Choose your desired spring rates
- > Recommended spring (70 N/mm) **FRONT**
- > Recommended spring FWD (70 N/mm), 4WD/Estate (80 N/mm) **REAR**
- > Use with original top mounts
- > Rebuildable
- > Weight reduction compared to original suspension: -10 kg
- > Corrosion salt spray tested (ISO 9227)
- > 2 year limited warranty
- > Cancellation kit available. For more info see page 107.



**OHLINS.COM**

ROAD & TRACK



# SUBARU

BRZ



**YEAR MODEL:** 2012-2020

**CHASSIS CODE:** ZC6 • **PART NO:** SUS MP21



## FEATURES

- > DFV (Dual Flow Valve)
- > McPherson strut **FRONT**
- > Conventional Shock Absorber **REAR**
- > Single bleed adjuster
- > Height adjustable (approx. 20 mm lower than standard) **FRONT**
- > Height adjustable (approx. 15 mm lower than standard) **REAR**
- > Choose your desired spring rates
- > Recommended spring (50 N/mm)
- > Use with original top mounts
- > Rebuildable
- > Corrosion salt spray tested (ISO 9227)
- > 2 year limited warranty



ROAD & TRACK

# SUBARU

## IMPREZA WRX STI • STI RACING



**YEAR MODEL:** 2007-2014

**CHASSIS CODE:** GR, GV • **PART NO:** SUS MI10



### FEATURES

- > DFV (Dual Flow Valve)
- > McPherson strut **FRONT**
- > Conventional Shock Absorber **REAR**
- > Single bleed adjuster
- > Height adjustable (approx. 20 mm lower than standard)
- > Coil springs (90 N/mm) **FRONT**
- > Coil springs (70 N/mm) **REAR**
- > Top mounts with camber adjustments (included) **FRONT**
- > Top mounts (included) **REAR**
- > Rebuildable
- > Corrosion salt spray tested (ISO 9227)
- > 2 year limited warranty
- > TÜV approved application



OHLINS.COM



ROAD & TRACK

# SUBARU

WRX STI



**YEAR MODEL:** 2015-2020

**CHASSIS CODE:** VA • **PART NO:** SUS MI10



## FEATURES

- > DFV (Dual Flow Valve)
- > McPherson strut **FRONT**
- > Conventional Shock Absorber **REAR**
- > Single bleed adjuster
- > Height adjustable (approx. 25 mm lower than standard) **FRONT**
- > Height adjustable (approx. 15 mm lower than standard) **REAR**
- > Coil springs (90 N/mm) **FRONT**
- > Coil springs (70 N/mm) **REAR**
- > Top mounts with camber adjustments (included) **FRONT**
- > Top mounts (included) **REAR**
- > Rebuildable
- > Corrosion salt spray tested (ISO 9227)
- > 2 year limited warranty
- > TÜV approved application





## ROAD & TRACK

# SUZUKI

## SWIFT SPORT



**YEAR MODEL:** 2004-2012

**CHASSIS CODE:** 2<sup>ND</sup> GEN, ZC31S • **PART NO:** SZS MI00



### FEATURES

- > DFV (Dual Flow Valve)
- > McPherson strut **FRONT**
- > Conventional Shock Absorber **REAR**
- > Single bleed adjuster
- > Height adjustable (approx. 30 mm lower than standard)
- > Coil springs (50 N/mm) **FRONT**
- > Coil springs (progressive) **REAR**
- > Use with original top mounts
- > Rebuildable
- > Corrosion salt spray tested (ISO 9227)
- > 2 year limited warranty
- > TÜV approved application



**OHLINS.COM**

ROAD & TRACK



# TOYOTA

## GT86



**YEAR MODEL:** 2012-2020

**CHASSIS CODE:** ZN6 • **PART NO:** SUS MP21



### FEATURES

- > DFV (Dual Flow Valve)
- > McPherson strut **FRONT**
- > Conventional Shock Absorber **REAR**
- > Single bleed adjuster
- > Height adjustable (approx. 20 mm lower than standard) **FRONT**
- > Height adjustable (approx. 15 mm lower than standard) **REAR**
- > Choose your desired spring rates
- > Recommended spring (50 N/mm)
- > Use with original top mounts
- > Rebuildable
- > Corrosion salt spray tested (ISO 9227)
- > 2 year limited warranty





ROAD & TRACK

# VOLKSWAGEN

## GOLF V

SEE ALL AVAILABLE MODELS ON PAGE 110

**YEAR MODEL:** 2003-2008

**CHASSIS CODE:** MK5, TYPE 1K • **PART NO:** VWS MT10



### FEATURES

- > DFV (Dual Flow Valve)
- > McPherson strut (55 mm width) **FRONT**
- > Conventional shock absorber **REAR**
- > Single bleed adjuster
- > Height adjustable (approx. 20 mm lower than standard)
- > Choose your desired spring rates
- > Recommended spring (70 N/mm) **FRONT**
- > Recommended spring FWD (70 N/mm), 4WD/Variant (80 N/mm) **REAR**
- > Use with original top mounts
- > Rebuildable
- > Weight reduction compared to original suspension: -10 kg
- > Corrosion salt spray tested (ISO 9227)
- > 2 year limited warranty
- > Cancellation kit available. For more info see page 107.



**OHLINS.COM**

ROAD & TRACK

# VOLKSWAGEN

## GOLF VI

SEE ALL AVAILABLE MODELS ON PAGE 110



**YEAR MODEL:** 2008-2012

**CHASSIS CODE:** MK 6, TYPE 5K • **PART NO:** WWS MT10

### FEATURES

- > DFV (Dual Flow Valve)
- > McPherson strut (55 mm width) **FRONT**
- > Conventional shock absorber **REAR**
- > Single bleed adjuster
- > Height adjustable (approx. 20 mm lower than standard)
- > Choose your desired spring rates
- > Recommended spring (70 N/mm) **FRONT**
- > Recommended spring FWD (70 N/mm), 4WD/Variant (80 N/mm) **REAR**
- > Use with original top mounts
- > Rebuildable
- > Weight reduction compared to original suspension: -10 kg
- > Corrosion salt spray tested (ISO 9227)
- > 2 year limited warranty
- > Cancellation kit available. For more info see page 107.



ROAD & TRACK

# VOLKSWAGEN

## GOLF VII

SEE ALL AVAILABLE MODELS ON PAGE 110

**YEAR MODEL:** 2012-2020

**CHASSIS CODE:** MK7 / MQB, TYPE 5G • **PART NO:** VWS MT21



### FEATURES

- > DFV (Dual Flow Valve)
- > McPherson strut (55 mm width) **FRONT**
- > Conventional shock absorber **REAR**
- > Single bleed adjuster
- > Height adjustable (approx. 20 mm lower than standard)
- > Choose your desired spring rates
- > Recommended spring (70 N/mm) **FRONT**
- > Recommended spring FWD (70 N/mm), 4WD/Variant (80 N/mm) **REAR**
- > Use with original top mounts
- > Rebuildable
- > Weight reduction compared to original suspension: -10kg
- > Corrosion salt spray tested (ISO 9227)
- > 2 year limited warranty
- > Cancellation kit available. For more info see page 107.
- > TÜV approved application



OHLSINS.COM

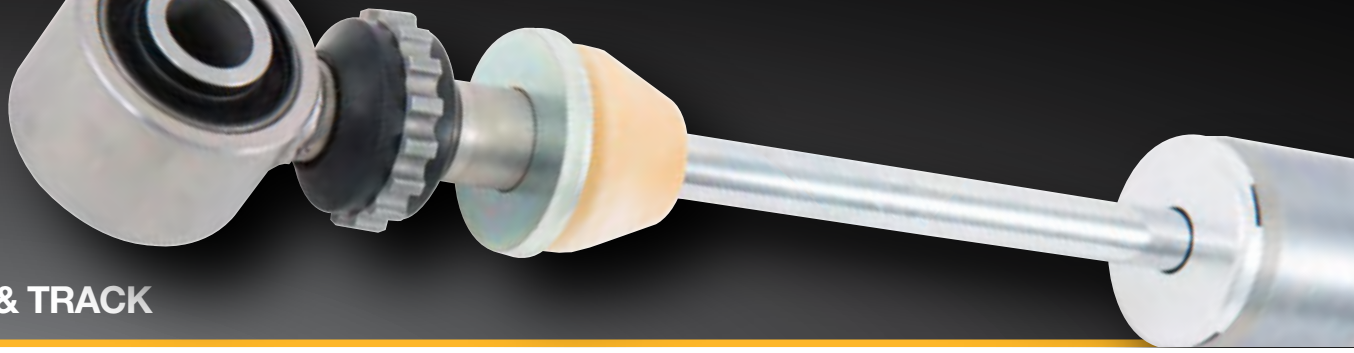

ROAD & TRACK

# VOLKSWAGEN

## SCIROCCO • SCIROCCO R



**YEAR MODEL:** 2008-2017

**PART NO:** VWS MT10



### FEATURES

- > DFV (Dual Flow Valve)
- > McPherson strut (55 mm width) **FRONT**
- > Conventional shock absorber **REAR**
- > Single bleed adjuster
- > Height adjustable (approx. 20 mm lower than standard)
- > Choose your desired spring rates
- > Recommended spring (70 N/mm) **FRONT**
- > Recommended spring FWD (70 N/mm), 4WD (80 N/mm) **REAR**
- > Use with original top mounts
- > Rebuildable
- > Weight reduction compared to original suspension: -10 kg
- > Corrosion salt spray tested (ISO 9227)
- > 2 year limited warranty



# CANCELLATION KIT

Öhlins Racing provides cancellation kits for cars equipped with originally equipped (OE) electronically adjustable shock absorbers. Using a cancellation kit from Öhlins prevents error messages from appearing at the display after switching shock absorbers on the car.

- > Avoids error messages when changing the shock absorber from OE.
- > The car ECU works in conjunction with this cancellation kit and all functions of the car remains as OE.
- > Can also be used for other manufacturers and OE aftermarket suspensions separately
- > The kit comes with Mounting instruction and one kit contains parts for whole car.

MODEL	CHASSI CODE	PART NO	KIT
AUDI A3/S3	8V	35020-23	Cancellation kit
AUDI RS3	8V	35020-24	Cancellation kit
AUDI A4/S4/A5/S5	B8	35020-19	Cancellation kit
AUDI RS4/RS5	B8	35020-21	Cancellation kit
AUDI R8	GEN 1	35020-17	Cancellation kit
AUDI R8	GEN 2	35020-28	Cancellation kit
AUDI TT/TTS/TT RS	8J	35020-24	Cancellation kit
BMW 3-SERIES	F30	35020-03	Cancellation kit EDC
BMW M3	F80	35020-02	Cancellation kit EDC
BMW M3	E92	35020-04	Cancellation kit EDC
BMW M4	F82	35020-02	Cancellation kit EDC
BMW Z4	E89	35020-05	Cancellation kit EDC
CHEVROLET CAMARO	5 <sup>th</sup> GEN	35020-16	Cancellation kit
FORD FOCUS RS	MK3	35020-18	Cancellation kit
HONDA CIVIC TYPE-R	FK2	35020-20	Cancellation kit
HONDA CIVIC TYPE-R	FK8	35020-25	Cancellation kit
HYUNDAI i30 N	PD	35020-26	Cancellation kit
LAMBORGHINI HURACÁN	-	35020-28	Cancellation kit
LAMBORGHINI HURACÁN PERFORMANTE	-	35020-28	Cancellation kit
NISSAN GT-R	R35	35020-06	Cancellation kit
PORSCHE 981	981	35020-07	Cancellation kit PASM
PORSCHE 981 GT4	981	35020-13	Cancellation kit PASM
PORSCHE 987	987	35020-08	Cancellation kit PASM
PORSCHE 991	991	35020-07	Cancellation kit PASM
PORSCHE 991 GT3	991	35020-13	Cancellation kit PASM
PORSCHE 997 CAB	997	35020-09	Cancellation kit PASM
PORSCHE 997	997	35020-10	Cancellation kit PASM
SEAT LEON	MK2	35020-14	Cancellation kit DCC
SEAT LEON	MK3	35020-15	Cancellation kit DCC
SKODA OCTAVIA	1Z	35020-14	Cancellation kit DCC
SKODA OCTAVIA	5E	35020-15	Cancellation kit DCC
VOLKSWAGEN GOLF V	1K	35020-14	Cancellation kit DCC
VOLKSWAGEN GOLF VI	5K	35020-14	Cancellation kit DCC
VOLKSWAGEN GOLF VII	5G	35020-15	Cancellation kit DCC



# ÖHLINS STICKERS

Öhlins stickers range gives you the option to personalize your car or shock. Stickers can be found through the Öhlins network.



## STICKERBOX

**Part No:** 10207-02

**Size:** 73 x 30 mm



## Ö YELLOW SMALL

**Part No:** 11221-08

**Size:** 17 x 32 mm



## Ö BLACK SMALL

**Part No:** 11221-09

**Size:** 17 x 32 mm



## Ö YELLOW

**Part No:** 11221-06

**Size:** 43 x 80 mm

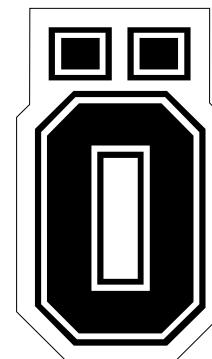

## Ö BLACK

**Part No:** 11221-07

**Size:** 43 x 80 mm



**ÖHLINS BLUE/YELLOW MEDIUM**

**Part No:** 01196-02

**Size:** 74 x 28 mm



**ÖHLINS BLACK/WHITE**

**Part No:** 01196-01

**Size:** 74 x 28 mm



**ÖHLINS BLUE/YELLOW MEDIUM**

**Part No:** 11221-01

**Size:** 210 x 79 mm



**ÖHLINS RETRO BLACK**

**Part No:** 11221-04

**Size:** 63 x 47 mm



**ÖHLINS BLACK/WHITE MEDIUM**

**Part No:** 11221-02

**Size:** 210 x 79 mm

(TRANSPARENT BACKGROUND)

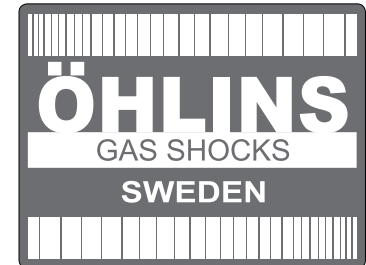

**ÖHLINS RETRO WHITE**

**Part No:** 11221-05

**Size:** 63 x 47 mm



## PRODUCT RANGE 2020

MODEL	CHASSIS CODE	YEAR	PART NO	TÜV APPROVED	PAGE
<b>AUDI</b>					
A3 • S3 • RS3	2 <sup>nd</sup> Gen, 8P	<b>A3</b> 2003-2012 • <b>S3</b> 2006-2012 • <b>RS3</b> 2011-2012	VWS MT10	YES	22
A3 • S3 • RS3	3 <sup>rd</sup> Gen, 8V	<b>A3</b> 2012-2020 • <b>S3</b> 2013-2020 • <b>RS3</b> 2015-2020	VWS MT21	YES	23
A4 • S4 • RS4	B8	<b>A4</b> 2008-2016 • <b>S4</b> 2008-2016 • <b>RS4</b> 2012-2016	AUS MS00	-	24
A5 • S5 • RS5	B8	<b>A5</b> 2007-2016 • <b>S5</b> 2007-2017 • <b>RS5</b> 2010-2017	AUS MS00	-	25
R8	1 <sup>st</sup> generation (V8, V10)	2006-2015	AUV MS00	-	26
R8	2 <sup>nd</sup> generation	2015-2019	AUV MT00	-	27
TT • TTS • TT RS	8J	<b>TT</b> 2006-2014 • <b>TTS</b> 2008-2014 • <b>TT RS</b> 2009-2014	VWS MT10	-	28
TT • TTS • TT RS	FV, 8S	<b>TT</b> 2014-2020 • <b>TTS</b> 2014-2020 • <b>TT RS</b> 2014-2020	VWS MT21	-	29
<b>BMW</b>					
1M	E82	2011-2013	BMZ MN01	YES	30
1-SERIES	E81, E82, E87, E88	2004-2011	BMS MI01	-	31
3-SERIES	E90, E91, E92, E93	2004-2013	BMS MI00	YES	32
3-SERIES	F30	2012-2018	BMS MP00	-	33
M2 • M2 COMPETITION	F87	2016-2019	BMS MR40	YES	34
M3	E46	2001-2005	BMS MI30	YES	35

MODEL	CHASSIS CODE	YEAR	PART NO	TÜV APPROVED	PAGE
M3	E90, E92	2007-2012	BMS MI40	YES	36
M3	F80	2014-2018	BMS MR40	YES	37
M4	F82	2014-2020	BMS MR40	YES	38
Z4	E89	2009-2011	BMS MP50	YES	39
<b>CHEVROLET</b>					
CAMARO	5 <sup>th</sup> Generation	2010-2015	CHS MP00	YES	40
<b>FIAT</b>					
124 SPIDER	-	2017-2020	FIZ MP00 + MAS MP00	-	41
<b>FORD</b>					
FOCUS RS	3 <sup>rd</sup> Generation	2015-2018	FOS MS00	-	42
MUSTANG	6 <sup>th</sup> Generation	2015-2018	FOS MP00	-	43
<b>HONDA</b>					
CIVIC TYPE-R	FD2	2006-2011	HOS MI30	-	44
CIVIC TYPE-R	FK2	2015-2017	HOS MT10	-	45
CIVIC TYPE-R	FK8	2017-2020	HOS MT00	YES	46
S2000	AP1, AP2	1999-2009	HOS MI21	YES	47
<b>HYUNDAI</b>					
i30 N	PD	2017-2020	HYS MT00	-	48
<b>LAMBORGHINI</b>					
HURACAN	-	2014-2020	AUV MT00	-	50
HURACAN PERFORMANTE	-	2017-2020	AUV MT00	-	50
<b>LEXUS</b>					
GS 460	URS190, URS191	2007-2011	LES MI00	-	52
IS-F	USE20R	2005-2013	LES MI00	-	53
IS 250	GSE21	2005-2013	LES MI00	-	53
IS 350	GSE20	2005-2013	LES MI00	-	53
<b>LOTUS</b>					
ELISE	-	2001-2011	LOV 1-4D00	-	54
EXIGE	-	2006-2011	LOV 1-4D00	-	54
<b>MAZDA</b>					
MX-5	NA/NB	1989-2005	MAS MI20	YES	55
MX-5	NC	2005-2015	MAS MI30	YES	56
MX-5	ND, RF	2016-2020	MAS MP00	YES	57
RX-7	FD3S	1991-2002	MAS MI10	-	58
RX-8	SE3P	2003-2008	MAS MI00	-	59
<b>MERCEDES-BENZ</b>					
G350 • G400 • G500 • G550 • G63 • G65	-	1979-2017	MEV 1S46-4S46	-	60
<b>MINI</b>					
COOPER S	R50/R53	2000-2006	BMS MI10	YES	61
COOPER	R56	2006-2013	BMS MI20	YES	62
<b>MITSUBISHI</b>					
LANCER EVO IV-VI	CN9A, CP9A	1996-2001	MIZ MI00 + MIS MI00	-	63
LANCER EVO VII-IX	CT9A	2001-2008	MIS MI00	YES	64

MODEL	CHASSIS CODE	YEAR	PART NO	TÜV APPROVED	PAGE
LANCER EVO X	CZ4A	2007-2016	MIS MI10	YES	65
<b>NISSAN</b>					
350Z	Z33	2002-2009	NIS MI00	-	66
SKYLINE GT-R	BCNR33, BNR34	1993-2002	NIS MI10	YES	67
GT-R	R35	2007-2020	NIZ MI30	YES	68
<b>OPEL • VAUXHALL</b>					
SPEEDSTER • VX220	-	2000-2005	OPV 1-4E00	-	69
<b>PORSCHE 911</b>					
911	-	1964-1989	POR 5L00, POR 6L00	-	70
<b>PORSCHE 718</b>					
BOXSTER • BOXSTER S • BOXSTER GTS	982	2016-2020	POS MP80	-	72
CAYMAN • CAYMAN S • CAYMAN GTS	982	2016-2020	POS MP80	-	73
<b>PORSCHE 981</b>					
BOXSTER • BOXSTER S • BOXSTER GTS	981	2012-2016	POS MP80	-	74
CAYMAN • CAYMAN S • CAYMAN GTS	981	2012-2016	POS MP80	-	75
CAYMAN GT4 • CAYMAN GT4 CLUB SPORT (TTX)	981	2016-2017	POF 5R00, POF 6R10	-	76
CAYMAN GT4	981	2016-2017	POZ MR90	-	77
<b>PORSCHE 986</b>					
BOXSTER • BOXSTER S	986	1996-2004	POS MR80	-	78
<b>PORSCHE 987</b>					
BOXSTER • BOXSTER S	987	2005-2012	POS MR80	-	79
CAYMAN • CAYMAN S • CAYMAN R	987	2005-2012	POS MR80	-	80
<b>PORSCHE 996</b>					
CARRERA • CARRERA CAB • TARGA	996	1999-2004	POZ MI00	YES	81
CARRERA 4/4S • CARRERA 4/4S CAB	996	1999-2005	POZ MN02	YES	82
TURBO • TURBO S • TURBO CAB • TURBO S CAB	996	2001-2005	POZ MN02	YES	83
GT2	996	1999-2005	POS MI10	YES	84
GT3 • GT3 RS	996	1999-2005	POS MI10	YES	85
<b>PORSCHE 997</b>					
CARRERA • CARRERA S • CARRERA CAB • CARRERA S CAB	997	2005-2015	POS MI20	YES	86
CARRERA 4/4S • CARRERA 4/4S CAB • TARGA 4/4S	997	2005-2012	POZ MN05	YES	87
TURBO • TURBO S • TURBO CAB • TURBO S CAB	997	2005-2012	POZ MN05	YES	88
GT2 • GT2 RS	997	2007-2011	POZ MN04	YES	89
GT3 • GT3 RS • GT3 RS 4.0	997	2007-2011	POZ MN04	YES	90
GT3 RS (TTX)	997	2007-2011	POF 5Q00, POF 6N01	-	91
<b>PORSCHE 991</b>					
CARRERA • CARRERA S	991.1, 991.2	2011-2019	POS MP70	-	92
CARRERA 4 GTS • CARRERA 4 GTS CAB	991.1, 991.2	2013-2019	POS MS00	-	93
TARGA 4/4S/4GTS	991.1, 991.2	2013-2019	POS MS00	-	93
TURBO • TURBO S • TURBO CAB • TURBO S CAB	991.1, 991.2	2013-2019	POS MS00	-	94
GT3 • GT3 RS (TTX)	991.1, 991.2	2013-2020	POF 5R00, POF 6R00	YES	95

MODEL	CHASSIS CODE	YEAR	PART NO	TÜV APPROVED	PAGE
<b>RENAULT</b>					
MÉGANE R.S. TROPHY 275 • MÉGANE R.S. 275 TROPHY-R *	-	2014-2017	8201603148 **	-	96
<b>SEAT</b>					
LEON • LEON CUPRA	MK2, 1P	2005-2012	VWS MT10	-	97
TOLEDO	MK3, 5P	2004-2009	VWS MT10	-	97
LEON • LEON ST • LEON CUPRA • LEON CUPRA ST	MK3, 5F	2012-2020	VWS MT21	-	98
LEON CUPRA R • LEON CUPRA R ST	MK3, 5F	2012-2019	VWS MT21	-	98
<b>SKODA</b>					
OCTAVIA • OCTAVIA RS	MK2, 1Z	2005-2013	VWS MT10	-	99
OCTAVIA • OCTAVIA RS	MK3, 5E	2013-2020	VWS MT21	-	100
<b>SUBARU</b>					
BRZ	ZC6	2012-2020	SUS MP21	-	101
IMPREZA WRX STI	GR	2007-2011	SUS MI10	YES	102
STI RACING	GV	2007-2014	SUS MI10	YES	102
WRX STI	VA	2015-2020	SUS MI10	YES	103
<b>SUZUKI</b>					
SWIFT SPORT	ZC31S	2004-2010	SZS MI00	YES	104
<b>TOYOTA</b>					
GT86	ZN6	2012-2020	SUS MP21	-	105
<b>VOLKSWAGEN</b>					
GOLF V GTI • GOLF V HB/VARIANT • GOLF V R32 • JETTA V	MK5, 1K	2003-2008	VWS MT10	-	106
GOLF VI • GOLF VI CAB/VARIANT • GOLF VI GTI HB/CAB	MK6, 5K	2008-2012	VWS MT10	-	107
GOLF VI R HB/CAB • JETTA VI	MK6, 5K	2008-2012	VWS MT10	-	107
GOLF VII GTD/GTE/GTI • GOLF VII HB/VARIANT	MK7, MQB, 5G	2012-2020	VWS MT21	YES	108
GOLF VII R HB/VARIANT	MK7, MQB, 5G	2012-2020	VWS MT21	YES	108
SCIROCCO • SCIROCCO R	-	2008-2017	VWS MT10	-	109



# FOR MORE CONTACT INFORMATION

Full information about which models Öhlins products are available for, please contact your local Öhlins distributor or visit

[www.ohlins.com/contact/distributors](http://www.ohlins.com/contact/distributors)



## AFRICA

**KENYA** Azar Anwar Motorsport

---

## ASIA

**CHINA** Gusto Technik Performance Parts Co. Ltd.

**HONG KONG** Gusto Technik Performance Parts Co. Ltd.

**INDONESIA** PT. Madani Sentra Multi Jasa

**JAPAN** Carrozzeria Japan Co. Ltd.

**MALAYSIA** High N Lubricant SDN BHD

**PHILIPPINES** Öhlins Asia Co., Ltd.

**SINGAPORE** Sporting Motors Pte Ltd.

**SOUTH KOREA** Neobis Int Co. Ltd.

**THAILAND** Öhlins Asia Co., Ltd.

**TAIWAN** Capricore Trading Co. Ltd.

**VIETNAM** Öhlins Asia Co., Ltd.

---

## EUROPE

**AUSTRIA** Öhlins DTC

**BELGIUM** Öhlins DTC

**BULGARIA** Öhlins DTC

**CROATIA** Öhlins DTC

**CYPRUS** Öhlins DTC

**CZECH REPUBLIC** Öhlins DTC

**DENMARK** Öhlins DTC

**ESTONIA** Öhlins Northern Europe

**FINLAND** Öhlins Northern Europe

**FRANCE** PFP Racing

**GERMANY** Öhlins DTC

**GREECE** Öhlins DTC

**HUNGARY** Öhlins DTC

**ITALY** Andreani Group International s.r.l

**LATVIA** Öhlins Northern Europe

**LITHUANIA** Öhlins Northern Europe

**LUXEMBURG** Öhlins DTC

**THE NETHERLANDS** Öhlins DTC

**NORWAY** Öhlins Northern Europe

**POLAND** FF-Sport

**PORTUGAL** Maxi-Shocks

**REPUBLIC OF IRELAND** Öhlins DTC

**ROMANIA** Öhlins DTC

**RUSSIA** Öhlins Northern Europe

**SLOVAKIA** Öhlins DTC

**SLOVENIA** Öhlins DTC

**SPAIN** Andreani MHS Ibérica SL

**SWEDEN** Öhlins Northern Europe

**SWITZERLAND** Öhlins DTC

**TURKEY** Öhlins DTC

**UKRAINE** Öhlins DTC

**UNITED KINGDOM** Öhlins DTC

---

## MIDDLE EAST

**DUBAI** Automotive Design & Development

**ISRAEL** G-Force Motorsport

**LEBANON** Lead Race Engineering

---

## NORTH & CENTRAL AMERICA

**CANADA** Öhlins USA Inc.

**MEXICO** Öhlins USA Inc.

**USA** Öhlins USA Inc.

---

## PACIFIC

**AUSTRALIA** Steve Cramer Products

**NEW ZEALAND** Kiwi Suspension Solutions

---

## SOUTH AMERICA

**ARGENTINA** Alpes Racing

**BRAZIL** JP3 Motorsport

**EQUADOR** RPM Imports

**PARAGUAY** Gotze Ingeniería S.A.



**Öhlins Racing AB** Instrumentvägen 8-10 Box 722 SE-19427 Upplands-Väsby, Sweden  
Phone: +46 (0)8 590 025 00 Mail: [info@ohlins.se](mailto:info@ohlins.se) Web: [www.ohlins.com](http://www.ohlins.com)

 **OHLINSRACING**

 **OHLINSRACING**

 **OHLINSAUTO**

 **OHLINSRACING**